

User Guide

Pantum BM5100 Series
Monochrome Laser Multifunction Printer

PANTUM

Preface

Welcome to the Pantum Series products!

We heartily appreciate your using of Pantum Series products!

To protect your vital interests, please carefully read the following statements.

For more information, please visit our official website (www.pantum.com).

Legal Notice

Trademark

Pantum and Pantum logos are registered trademarks of Zhuhai Pantum Electronics Co.,Ltd.

Microsoft[®], Windows[®], Windows Server[®] and Windows Vista[®] are trademarks registered by Microsoft Corporation in the United States or other countries/regions.

Apple, AirPrint, Mac, and macOS are trademarks of Apple Inc., registered in the U.S. and other countries. Use of the Works with Apple badge means that an accessory has been designed to work specifically with the technology identified in the badge and has been certified by the developer to meet Apple performance standards.

The Mopria™ word mark and the Mopria™ Logo are registered and/or unregistered trademarks of Mopria Alliance, Inc. in the United States and other countries. Unauthorized use is strictly prohibited.

Wi-Fi Direct, Wi-Fi Protected Setup (WPS), WPA, WPA2, WPA3 and Wi-Fi Protected Access are marks of the Wi-Fi Alliance.

The ownership to the names of the software in this User Guide belongs to their respective companies in accordance with corresponding license agreement, and they are referred for instructions only.

All other product and brand names herein may be the registered trademarks, trademarks or service marks of their respective owners, and they are referred for instructions only.

Copyright

The Copyright of this User Guide is owned by Zhuhai Pantum Electronics Co., Ltd.

It is prohibited to copy, translate, modify and transmit this User Guide by any means or in any form without the prior written consent of Zhuhai Pantum Electronics Co., Ltd.

Version: V3.1

Disclaimer

For a better user experience, Zhuhai Pantum Electronics Co., Ltd. reserves the right to make changes to the User Guide. The information contained herein is subject to change without notice. Users are responsible for any damages arising from failing to follow this User Guide.

Meanwhile, except the express warranty made in the product maintenance manual or service commitment, Zhuhai Pantum Electronics Co., Ltd. does not make any express or implied warranty or guarantee to this User Guide (including composing or words).

Using this product to copy, print, scan certain documents or images or make other forms of operations may be prohibited by the local laws. If you are uncertain about the legality of using this product for certain documents or images, you should consult your legal advisor in advance.

Safety Precautions

Disconnect the power supply

The product should be placed close to or easily accessible to power sockets, so as to allow easy disconnection of power supply!

Laser Safety

The laser radiation is harmful to the human body. Since laser components are completely sealed in the printer, laser radiation will not leak. To avoid laser radiation, please do not randomly disassemble the printer!

The printer follows the provisions of Class 1 laser products under CFR standard.



The printer has a Class III b laser diode, which has no laser radiation leakage among laser components.

The laser components shall comply with the requirements of: U.S. Code of Federal Regulations, 21 CFR 1040, IEC 60825-1.

The following label is attached to the laser components inside the printer:











or

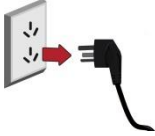

Safety Warning

Please note the following safety warnings before using the printer:

 Warning	
 There is high-voltage electrode inside the printer. Before cleaning the printer, make sure the power is turned off!	
 Plugging and unplugging the power cord plug with a wet hand can result in an electric shock.	
 The fuser unit is hot when and after printing. Touching the fuser unit (the shaded area as shown) may cause burns!	
 The fuser unit is attached with a high temperature warning label. Please do not remove or damage this label.	

Precautions

Precautions before Using the Printer:

1. Read and understand all instructions.
2. Familiarize yourself with the basic principles associated with operating electrical appliances.
3. Comply with all warnings and instructions marked on the equipment or specified in the manual supplied with the equipment.
4. If the operating instructions conflict with the safety information, please refer back to the safety information, as you may have misunderstood the operating instructions. If you cannot resolve the conflicts, please call the Customer Service Hotline or contact a service representative for help.
5. Before cleaning the equipment, remove the power cord from the AC power supply outlet. Do not use liquid or aerosol cleaners.
6. Please make sure that the equipment is put on a stable desktop surface to avoid serious damage caused by the falling of the equipment.
7. Do not put the equipment near a radiator, an air conditioner, or a ventilation pipe.
8. Do not put any articles on the power cord. Do not put the equipment at the place where its power cord could be stepped on by people.
9. Outlets and extension cords must not be overloaded. This may reduce performance and could result in fire or electric shock.
10. Do not allow pets to chew on the AC power cord or the computer interface cable.
11. Do not allow sharp objects piercing equipment slot, so as to avoid contact with the high-voltage device, which otherwise may result in fire or electric shock. Take care not to spill liquids onto the equipment.
12. Do not disassemble the equipment so as to avoid the risk of electric shock. Necessary repairs may only be carried out by professional maintenance personnel. Opening or removing the cover could result in an electric shock or other potential hazards. Incorrect disassembly and assembly could also result in an electric shock during future use.
13. If any one of the following occurs, disconnect the equipment from the computer and pull out the power cord from the AC wall socket and contact a qualified member of the service personnel for maintenance:
 - Liquid has been spilled into the equipment.
 - The equipment has been exposed to rain or water.
 - The equipment falls, or the cover is damaged.
 - Significant changes in the equipment's performance.
14. Only adjust the control mentioned in the instructions. Incorrect adjustment of other controls may result in damage and mean that professional maintenance personnel need to spend more time fixing it.
15. Do not use the equipment in a thunderstorm so as to avoid the risk of an electric shock. If possible, pull out the AC power cord during a thunderstorm.
16. If you continuously print multiple pages, the surface of the tray will become very hot. Take care not to touch this surface, and keep children away from this surface.
17. The signal wire of the device connected with the printer can not be connected to the outdoors.
18. Please ensure timely ventilation in case of a prolonged use or printing huge amounts of documents in a poorly ventilated room.

19. In standby status, the product will automatically enter into the power saving (sleep) mode if it does not receive any job order for a while (such as 1 minute); and it can realize zero power consumption only if it has not been connected with any external input power supply.
20. As the Class 1 equipment, the product must be connected to the power supply outlet with protective grounding line when using.
21. This product should be placed according to the shipping marks on the product package box during delivery.
22. This product is a kind of low-voltage equipment. When using this product below the specified voltage range, please refer to the product precautions or call Pantum Aftersales Service Centre, if the toner comes off the printed contents, or the equipment starts slowly.
23. This product is sold as a complete machine. The consumers can go to Pantum Aftersales Service Centre to purchase parts they need. If the product sold is inconsistent with the package list, please go to the specified Aftersales Service Centre to solve the problem.
24. Install this product in a place with the temperature between 10°C and 32°C and the relative humidity between 20% and 80%.
25. For security and other reasons the printer may switch to intermittent printing after a certain amount of continuous printing.
26. This device complies with Part 15 of the FCC Rules. Operation is subject to the following two conditions:
- (1) this device may not cause harmful interference, and
 - (2) this device must accept any interference received, including interference that may cause undesired operation.
27. This equipment complies with FCC radiation exposure limits set forth for an uncontrolled environment. This equipment should be installed and operated with minimum distance 20cm between the radiator and your body. This transmitter must not be co-located or operating in conjunction with any other antenna or transmitter.
28. NOTE: This equipment has been tested and found to comply with the limits for a Class B digital device, pursuant to Part 15 of the FCC Rules. These limits are designed to provide reasonable protection against harmful interference in a residential installation. This equipment generates, uses and can radiate radio frequency energy and, if not installed and used in accordance with the instructions, may cause harmful interference to radio communications. However, there is no guarantee that interference will not occur in a particular installation.
- If this equipment does cause harmful interference to radio or television reception, which can be determined by turning the equipment off and on, the user is encouraged to try to correct the interference by one or more of the following measures:
- Reorient or relocate the receiving antenna.
 - Increase the separation between the equipment and receiver.
 - Connect the equipment into an outlet on a circuit different from that to which the receiver is connected.
 - Consult the dealer or an experienced radio/TV technician for help.
29. Warning: Changes or modifications to this unit not expressly approved by the party responsible for compliance could void the user's authority to operate the equipment.

30. The power consumption of the product with wireless function is 5W/without wireless function is 2W in networked standby if all wired network ports are connected and all wireless network ports are activated.

31. Shielded cables must be used with this unit to ensure compliance with the Class B FCC limits.

32. Administrative Regulations on Low Power Radio Waves Radiated Devices.

For any certified low-power RF devices, any company, firm, or user is not allowed to change the frequency, increase the power, or change the characteristics and functions of the original design without approval.

The use of low-power RF device shall not affect flight safety and interfere with legal communication; if interference is found, it shall be immediately deactivated and improved until no interference is required.

Legal communication in the preceding paragraph refers to radio communications operating in accordance with the provisions of the Telecommunications Act.

Low-power RF device must withstand interference from legal communications or radiological electrical equipment for industrial, scientific, and medical use.

33. The operations near the radar system shall not be influenced.

34. Please keep this User Guide properly.

Legal Information



This symbol indicates that, at the end of your product's life, it must not be discarded as domestic waste. Instead, you should dispose of your used equipment at a designated collection point for the recycling of waste electrical and electronic equipment. Ref: EU Directive 2002/96/EC on Waste Electrical and Electronic Equipment (WEEE). Please contact your distributor / supplier for further information.



This product is suitable for indoor use only.



European Community (EC) directives conformity

This product complies with the protection requirements of EC directives 2014/30/EU and 2014/35/EU on the approximation and harmonization of the laws of the Member States relating to electromagnetic compatibility and safety of electrical equipment designed for use within certain voltage limits.

Radio Equipment directive 2014/53/EU only for models ending with suffix "W".

The manufacturer of this product is: Zhuhai Pantum Electronics Co., Ltd., Building 02,06 and 08, No.888 Shengping Avenue, Pingsha Town, Zhuhai City, Guangdong Province, 519000 PR China.

A declaration of conformity to the requirements of the Directives is available upon request from the Authorized Representative.

This product satisfies the Class B limits of EN 55032 / EN 55035 and safety requirements of EN 62368-1.

Supplier's Declaration of Conformity

47 CFR § 2.1077 Compliance Information

Unique Identifier

Trade Name: Pantum

Model No.: BM51***** (suffix *: A-Z, 0-9, hyphen or blank)

Responsible Party – U.S. Contact Information

Company Name: PANTUM (USA) CO.,LTD

Office address: 13875 Ramona Ave., Chino, CA 91710

TEL: 626-965-6662

FCC Compliance Statement

This device complies with Part 15 of the FCC Rules. Operation is subject to the following two conditions: (1) This device may not cause harmful interference, and (2) this device must accept any interference received, including interference that may cause undesired operation.

USA Only

Table of Content

01 Before Using the Printer	1
Product View	1
Control Panel.....	5
02 Paper and Print Media	7
Paper Specification	7
Loading Paper	8
Load paper in automatic tray	8
Load paper in multi-purpose tray.....	10
Load paper in optional tray	12
Paper and Manuscript Use Process.....	15
Scanning With Tablet.....	15
Scan with the automatic document feeder (ADF)	17
03 Driver installation and uninstallation.....	19
Driver Setup.....	19
One-click Installation(For Windows and macOS).....	19
Plug and Play installation.....	20
Uninstall Driver.....	21
Method to uninstall driver under Windows	21
Method to uninstall driver under macOS	21
04 Wired network setup (applicable to wired network models)	22
Set IP Address.....	22
Automatic Setting	22
Manual Setting	22
05 Wireless network setup (applicable to Wi-Fi models).....	23
Wireless network setup tools	23
Preliminary preparations	23
Setup methods of wireless network setup tools.....	23
How to disable the Wi-Fi network connected	23
06 Web server.....	24
Visit the embedded Web server.....	24
07Print.....	25
Print Function.....	25
Print Settings.....	26
Setting the printing parameters	26
Automatic Two-Sided Printing	26

Mute Printing.....	29
Auto shut-off setting.....	30
08 Copying.....	31
Copying function.....	31
Common copying setting.....	31
Multipage.....	32
Collated copy	33
Duplex copy.....	33
ID card copying setting.....	34
Receipt setting	34
09 Scan	35
Pull Scan.....	35
Windows system scan.....	35
macOS System Scan	36
Push Scan	36
10 outline Maintenance.....	41
Cleaning the Printer	41
Toner cartridge and drum component maintenance	46
About toner cartridge and drum component.....	46
Replace toner cartridge and drum component.....	47
Installing and removing the optional tray	51
Installing optional tray	51
Removing the optional tray	53
Updating the optional tray status	54
11 Troubleshooting.....	55
Cleaning Jammed Paper.....	55
Middle jam.....	55
Paper Jam in the Fuser Unit.....	58
Duplex Unit Jam.....	62
A paper jam occurs on the automatic document feeder (ADF)	64
Paper jam of auto feed tray	66
Paper jam of multi-purpose tray	67
Paper jam of optional tray.....	68
Software Failure.....	71
Error Message.....	72
Common Troubleshooting	73
Common Trouble	73

Image Defects	75
12 Product Specifications	79
Overview of the Specifications	79
Print Specifications	80
Copy Specifications	80
Scan Specifications	80

01 Before Using the Printer

Product View

Side view

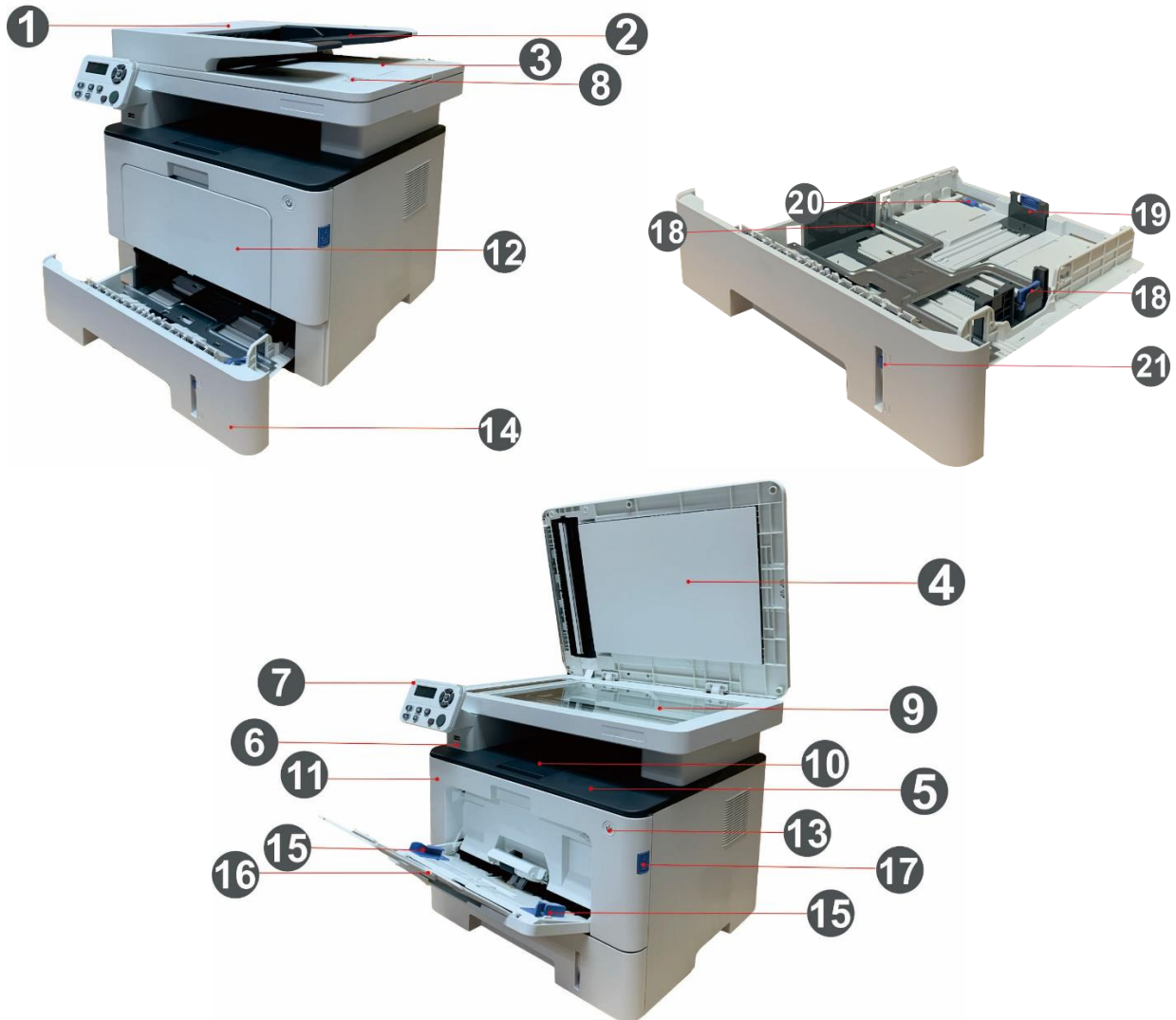

1	Cover of automatic document feeder	This is used to remove the paper jammed in scanning for the ADF.
2	Feed tray of automatic document feeder	This is used to place originals scanned from the ADF.
3	Exit tray of automatic document feeder	Prevent originals scanned from falling off.
4	Cover of scanner	Open the cover of scanner to place the scanned originals on its glass plate.

5	Output Bin	For storing the printed paper.
6	Front USB interface	This is used to scan to an U-disk without a computer.
7	Control Panel	Indicate printer status to conduct set operation.
8	NFC (Near Field Communication) label	Touch this label on mobile device to download or start Pantum printer App and connect Wi-Fi Directly.
9	Glass Platen	This is used to place originals scanned from platen.
10	Output Tray	To prevent the printed paper from falling.
11	Front Cover	To open the front cover to take out the laser toner cartridge.
12	Multipurpose feed tray	For placing media to be printed in multi-purpose tray.
13	Power switch	Turn the power on or off and press this button under Ready state to enter energy-saving mode. Press and hold this button for more than 2s to turn the printer power off.
14	Automatic Feeder Tray	For placing mediums that are printed in auto feed tray.
15	Paper width guide of multi-purpose tray	Slide paper deflector to adapt to paper width.
16	Paper length guide of multi-purpose tray	Adjust the paper length guide to match the paper length.
17	Front cover button of printer	For opening and closing the front cover of the printer.
18	Paper width guide of tray	Slide paper width deflector to adapt to paper width.
19	Paper length guide of tray	Slide paper length deflector to adapt to paper length.
20	Clip of extended tray of the paper tray	For adjustment of length extension of the tray .
21	Paper Level Indicator	Indicate the amount of paper left in automatic tray.

Rear View

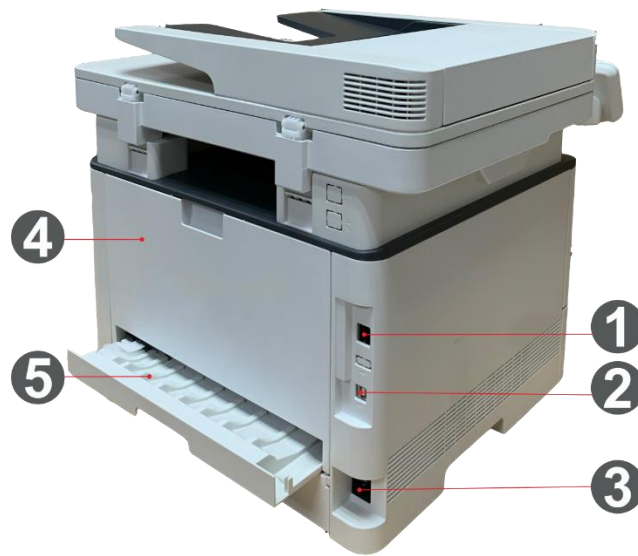

1	Network Interface	For connecting product to network with network cable.
2	USB Interface	For connecting product to computer with USB cable.
3	Power Interface	For connecting product to power with power cord.
4	Rear Cover	For paper release when it gets jammed.
5	Duplex Printing Unit	For paper feed at duplex printing and paper release when paper gets jammed at duplex printing.

Note: Printer appearance may differ because of various models and functions, so the schematic diagram is only for your reference.

Optional tray

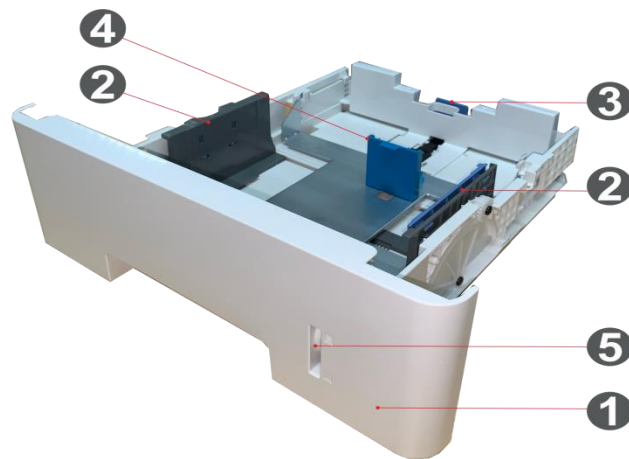

1	Optional tray	For placing media to be printed in optional tray.
2	Paper width guide of tray	Slide paper width deflector to adapt to paper width.
3	Paper length guide of tray	Slide paper length deflector to adapt to paper length.
4	A5/A6 stopper	Install the stopper to match the A5 L/A6 paper size.
5	Paper Level Indicator	Indicate the amount of paper left in optional tray.

Note : • The printer can support up to two optional trays.

- If you want to buy optional trays, please contact the local dealer who has purchased the printer.
- Printer appearance may differ because of various models and functions, so the schematic diagram is only for your reference.
- If you need to print A5 L, A6 size, please install A5/A6 stopper on the tray first. For installation, please refer to the Quick Installation Guide for optional accessories.
- A5/A6 stopper is not available separately, please keep it properly.

Control Panel

The layout of the printer control panel is shown below:

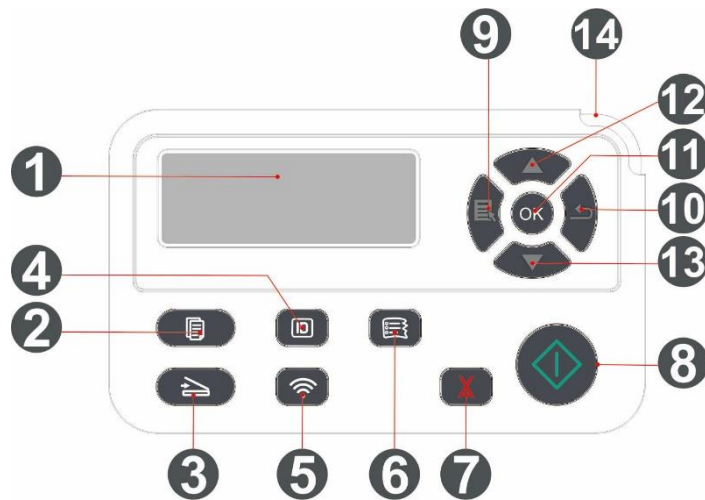

No.	Name	Functions
1	LCD Display	Display operation interface and product information.
2	Copy Button	Press this button to enter into copy mode.
3	Scan Button	Press this button to enter into scan mode.
4	ID Card Copy Button	Press this button to enter into ID Card Copy mode.
5	Wi-Fi button	Short press Wi-Fi button to turn on direct Wi-Fi connection of the printer and automatically print out "Mobile Device Wi-Fi Connection Wizard" page (for models with Wi-Fi function only). Long press Wi-Fi button for over 2s to start WPS when Wi-Fi is not connected or to disconnect Wi-Fi when it has already been connected (for models with Wi-Fi function only). Open save toner function(applicable to non-Wi-Fi model only).
6	Bill Copy Button	Press this button to enter into Bill Copy mode.
7	Cancel	Execute cancel operation Idle state interface under copy mode, to reset the "Number of Copies" to 01.
8	Start Button	This is used to start relevant operations after finishing operation settings. In case of a feed failure, please press this key for pick-up and printing again.
9	Menu	Open the main menu of control panel
10	Back	Return to the previous menu.
11	OK	Confirm the selection on screen.
12	UP	Scroll through the menus and options . Increase 1 copy on the ready interface of Copy mode.

13	Down	Scroll through the menus and options . Decrease 1 copy on the ready interface of Copy mode.
----	------	--

14	Status Light	Indicate the status of printer.
----	--------------	---------------------------------

02 Paper and Print Media

Paper Specification

Automatic Feeder Tray	Media Type	Plain paper(70~105g/m ²),thin paper(60~70g/m ²),thick Paper(105~120g/m ²),Transparent film,Recycled Paper
	Media size	A4, Letter, Legal, Folio, Oficio, Statement, Executive, JIS B5, ISO B5, A5, A5 L, A6, B6, 16K, Big 16K, 32K, Big 32K, Custom
	Media weight	60~120 g/m ²
	Maximum capacity of the tray	250 pages (80 g/m ²)
Multipurpose feed tray	Media Type	Plain paper(70~105g/m ²),thin paper(60~70g/m ²),thick paper(105~120g/m ²),Carton paper,Label paper, Envelope,Thicker
	Media size	A4, Letter, Legal, Folio, Oficio, Statement, Executive, JIS B5, ISO B5, A5, A5 L, A6, B6, Monarch Env, DL Env, C5 Env, NO.10 Env, C6 Env, Japanese Postcard, Postcard, ZL, 16K, Big 16K, 32K, Big 32K, Yougata4, Younaga3, Nagagata3, Yougata2, Custom
	Media weight	60~200 g/m ²
	Maximum capacity of the tray	60 pages(80 g/m ²)
Optional Tray 1/2	Media Type	Plain paper(70~105g/m ²),thin paper(60~70g/m ²),thick Paper(105~120g/m ²),Recycled Paper
	Media size	A4, Letter, Legal, Folio, Oficio, Statement, Executive, JIS B5, ISO B5, A5, A5 L, A6, 16K, Big 16K, Custom
	Media weight	60~120 g/m ²
	Maximum capacity of the tray	550 pages(80 g/m ²)

Note: • 80 g/m² standard paper is recommended for this printer.

- It is not recommended to use special paper extensively, which may affect the service life of the printer.
- The print media that does not meet the guidelines listed in this User Guide may result in poor print quality, increased paper jam and excessive wear of the printer.
- Properties such as weight, composition, texture and humidity are important factors affecting the printer performance and output quality.

Please note the following matters when selecting the print media:

1. Desired print effect: The print media selected should meet the requirement of the print tasks.
2. Surface smoothness: The smoothness of the print media may affect the sharpness of the print outcome.
3. Some print media may meet all the use guidelines contained herein, but they still can not bring satisfactory effect. This may be due to incorrect operation, inappropriate temperature and humidity, or other factors beyond the control of Pantum. Before purchasing large quantities of print media, make sure that the print media meets the specifications specified in this User Guide.

Loading Paper

Note: • Printer appearance may differ because of various models and functions, so the schematic diagram is only for your reference.

Load paper in automatic tray

1. Slide out the automatic feeder tray from the printer.



2. Slide the clip of extended tray of auto feed tray, paper length deflector and paper width deflector to the slot suitable for paper size, in order to match paper length and width.



Note: • Do not overly squeeze the "paper length guide" and "paper width guide", otherwise it could easily lead to deformation of paper.

3. Before loading paper, please unfold the stacked paper to avoid a paper jam or feed error, and then load the paper into the tray print-side down. The automatic feeder tray can be loaded up to 250 pages, 80g/m² paper.

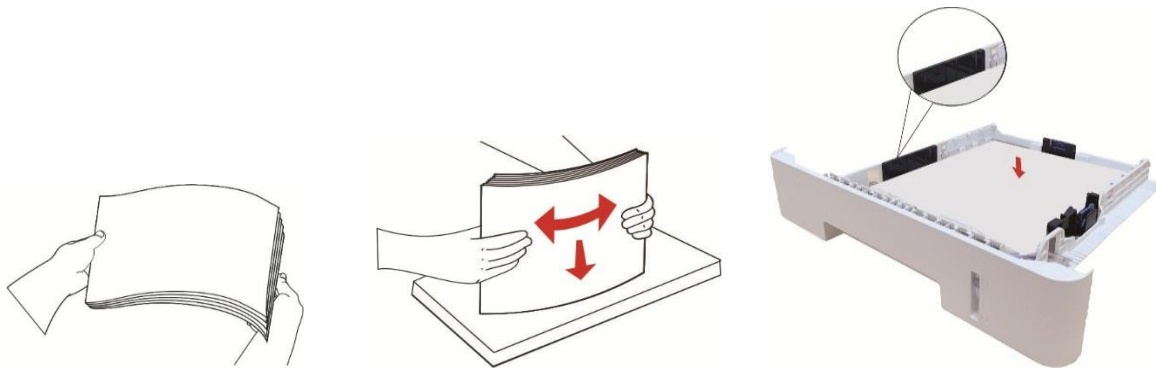

4. Raise the output tray to avoid the printed paper from slipping and falling, or immediately remove the printed document after the printing is complete.



- Note:** • It is recommended that you raise the output tray to prevent the paper from slipping and falling after printing. If you choose not to raise the output tray, we recommend that you immediately remove the printed paper from the printer.
- If more than 250 pages (80 g/m²) are put inside the auto feed tray at one time, paper jam or paper feed failure will be led to.
 - If carrying out single-sided printing, please make sure that the side to be printed (the blank side) is face down.

Load paper in multi-purpose tray

1. Open the multipurpose feed tray.



2. Slide the paper guide of the multipurpose feed tray to match both sides of the paper. Do not apply excessive force; otherwise, paper jamming or tilting may occur.



3. Unfold the stack of paper for feeding to avoid jamming or feeding error, place the side of paper to be printed upwards into the automatic feed tray. The multipurpose feed tray can hold up to 60 pieces of 80g/m² paper.

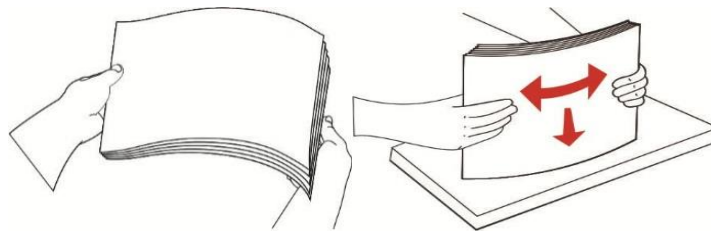

4. Place the printing media flatly into multipurpose feed tray with both hands.

5.Raise the output tray to avoid the printed paper from slipping and falling, or immediately remove the printed document after the printing is complete.



- Note** :
- Place the side of paper to be printed upwards into the multipurpose feed tray and ensure top of the paper enters the tray first.
 - After printing, please take out printed papers output from printer immediately. Stacked papers or envelops will lead to paper jam or wrapped paper.

Load paper in optional tray

- Note** :
- For the installation of optional trays, please refer to [“Installing optional tray”](#) or the Installation Guide supplied with the optional trays.
 - Before you use it, please remove the A5/A6 stopper before loading paper.

1. Pull out the optional tray completely from the printer.



2. Slide the paper length guide and paper width guide to the slot suitable for paper size, to match paper length and width.



Note : Do not overly squeeze the “paper length guide” and “paper width guide”, otherwise it could easily lead to deformation of paper.

- To load Legal size paper, press inwards the Release button at the rear end of the tray and pull out the rear end of the tray to lengthen the tray.

3. Before loading paper, please unfold the stacked paper to avoid a paper jam or feed error, and then load the paper into the tray print-side down. An optional tray can hold up to 550 pieces of 80g/m² paper.

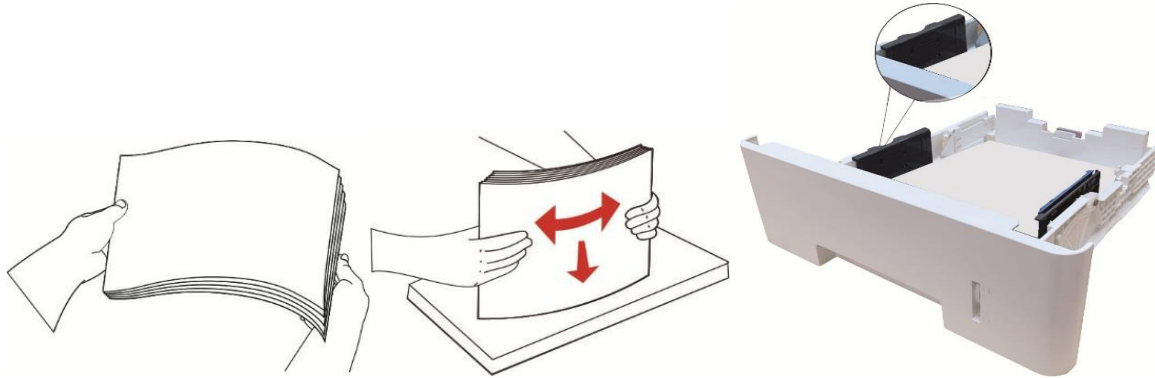

4. Raise the output tray to avoid the printed paper from slipping and falling, or immediately remove the printed document after the printing is complete.



Note: • If more than 550 pieces of paper (80g/m²) are put inside the optional tray at one time, it will lead to paper jam or paper feed failure.

• For single-sided printing, please make sure that the side to be printed (the blank side) faces down.

Paper and Manuscript Use Process

Manuscript requirements:

Source	Type	Size
Automatic document feeder (ADF)	Plain paper	A4, A5, B5, A6, Letter, Folio, Executive, Legal
Platen	Plain paper, Thin Paper, Thick Paper, Transparent Film, Carton Paper, Label Paper, Envelope, Thicker, Recycled Paper	A4, A5, B5, Letter, Full Scanning Platen, Executive, Custom

Scanning With Tablet

Note: • Printer appearance may differ because of various models and functions, so the schematic diagram is only for your reference.

Steps of Use:

1. Lift up the scanner cover.



2. Load the manuscript face down.



3. Align the manuscript to match the appropriate paper size.

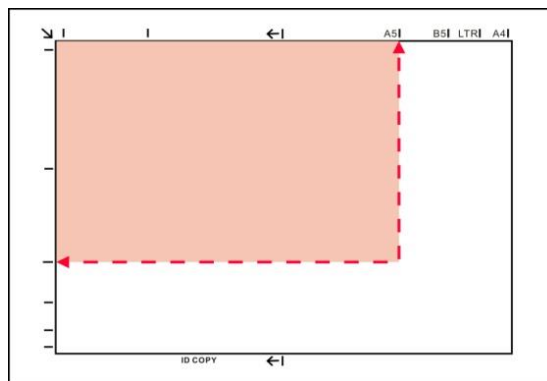

- Note:**
- If the manuscript does not match with any size marker, please align the upper-left corner of the manuscript with the arrow.
 - Make sure there is no document in the ADF. If a document is detected in the ADF, it will be more preferential than that on glass platen.

4. Close the scanner cover gently.



- Note:**
- Please put the paper or document on the scanner glass after the glue, ink or correction fluid are completely dried.
 - Rough textured, uneven, oil stained and extremely smooth paper will make printing effect poor.
 - Please make sure that there is no dust, fluff, etc. on the paper.
 - Paper shall be put on a flat surface and stored under a cool and dry environment.
 - To avoid influencing the definition, please don't open the scanner cover during scanning with the platen.

Scan with the automatic document feeder (ADF)

1. Put the original into the ADF with its front upward and top fed first.



2. Adjust the document guide till it gets close to the paper stack.



Note: The ADF supports feeding 50 pieces of paper at most that should be fed one by one.

03 Driver installation and uninstallation

Driver Setup

This device supplies driver setup applications for Windows and macOS. We recommend One-click installation, which helps you install the driver automatically in a faster and easier way. Should you encounter trouble when using the One-click installation, you may try more setup methods.

Note: • Driver installation interface may differ because of different models and functions, so the schematic diagram is only for your reference.

One-click Installation(For Windows and macOS)

One-click installation offers installation options via "Wi-Fi", "USB", and "Wired Network". You may select the one you're familiar with the most according to the connection methods supported by your printer.

Connect printer via Wi-Fi

Configure Wi-Fi and install driver via USB cable

1. Computer is already connected to router via Wi-Fi.

Note: • Printers only support 2.4 GHz network when it is configured with Wi-Fi network.

• You can print "Network configuration page" to confirm printer network connection status to see if printer is connected with network

2. Connect the printer to computer via USB cable, then power the printer on.
3. Place the attached installation CD in the computer CD-ROM:
4. Read and agree to the terms contained in the End User License Agreement and the Privacy Policy, click the "Next" button in the lower right corner of the interface to enter the driver installation interface.

5. Click on "One-click installation" button under Wi-Fi to install the driver.

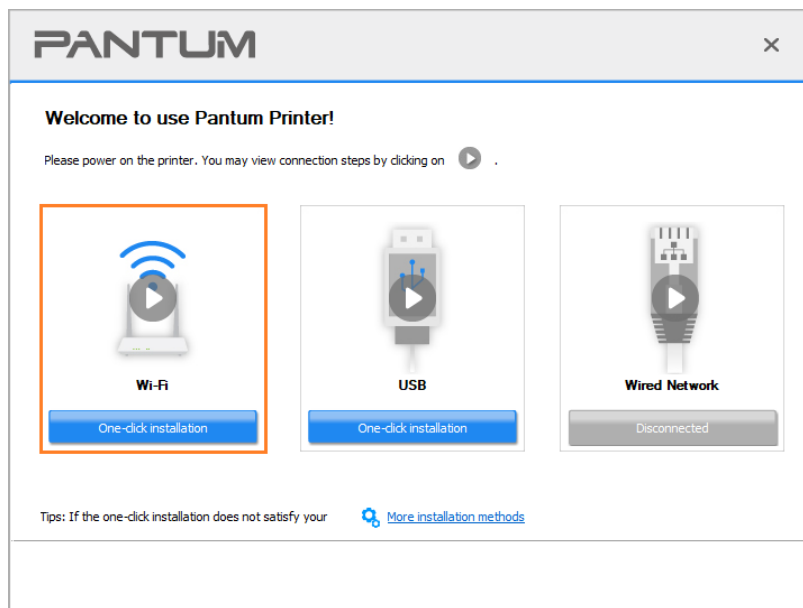

Note: • You can put your mouse cursor in the "One-click installation" button to check the popup information in order to confirm if the current printer is the one you need to install through IP address before you click the button.

6. After the installation, click "Print & Test Page" button. If your printer prints the test page successfully, it means that you have installed the driver correctly. (If you need to install the OCR software under the Windows system, please install it when the computer is connected to the Internet.)

Plug and Play installation

You can complete the driver installation via the "plug and play" function. The specific steps are as follows:

1. Connect the printer to the computer via a USB cable, and the driver will be automatically installed without CD/DVD.

Note: • Make sure that the printer and computer are in a ready state.

• Make sure that the operating system is up to date and the network is connected.

2. You can go to the "View Devices and Printers" page to confirm whether the installation was successful.

Uninstall Driver

Method to uninstall driver under Windows

Windows 7 is taken as the example in the following operation. The information on your computer screen may differ because of multiple operating systems.

1. Click the Start menu of computer and then click All programs.
2. Click Pantum, and then Click Pantum XXX Series.

Pantum XXX Series where XXX represents product model.

3. Click uninstall to delete the driver according to instructions on uninstall window.
4. Restart computer after finishing unloading.

Method to uninstall driver under macOS

macOS10.14 is taken as the example in the following operation. The information on your computer screen may differ because of multiple operating systems.

1. Click "Go" - "Applications" - "Pantum" - "Utilities" - "Pantum Un-install Tool".
2. Delete the driver as instructed in the pop-up Uninstall window.
3. Uninstall complete.

04 Wired network setup (applicable to wired network models)

In case printers support wired network printing, they can be connected to network to control printer to print in wired network mode.

Set IP Address

The IP address of the printer may be automatically obtained through DHCP function or set manually.

Automatic Setting

DHCP automatic setting function is enabled by default on the printer.

1. Connect the printer to the network through a network cable and complete the startup preparation work.
2. The printer will receive the IP address assigned by server automatically. It may take server minutes to receive IP address under the influence of network environment.

You can check the IP address of printer by printing "Network setup page" out or check network information by viewing the control panel of printer. If the IP address is not listed, please check network environment and then try again after waiting for several minutes.

Note: • If DHCP server fails to assign IP address automatically, the printer will get the link-local address assigned by printer automatically: 169.254.xxx.xxx.

Manual Setting

To set up IP address for printer through the control panel of printer manually.

To set up IP address for printer through the embedded Web server manually.

05 Wireless network setup (applicable to Wi-Fi models)

Wireless network connection type is divided into basic structure mode and Wi-Fi Direct mode.

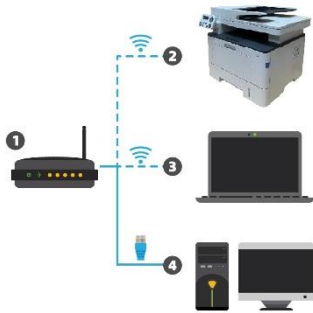

Basic structure mode: connecting to a wireless device via router

1. Access point (wireless router)
2. Wireless network printer
3. Computer connecting to access point via wireless network
4. Computer connecting to access point via network cable



Wi-Fi Direct mode: wireless client is connecting to a printer with Wi-Fi function

1. Wireless network printer
2. Wireless client is directly connecting to a wireless network printer

Wireless network setup tools

If your computer has been installed with a driver and had been connected to wireless network, but the wireless network was changed, you can set it again with wireless network setup tools.

Preliminary preparations

1. Access point (wireless router).
2. A computer that has been connected to network.
3. A printer that has wireless network function.

Setup methods of wireless network setup tools

Take the wireless network setup tool in computer.

- 1) **Windows system:** Click the "Start menu" – "All programs" - "Pantum" – Product name – "Wireless network setup tool".
- 2) **macOS system:** click "Go" - "Applications" - "Pantum" - "Utilities" - "Wireless Network Configuration Tool" on the computer Finder menu bar.

How to disable the Wi-Fi network connected

Connect the wireless network in infrastructure mode by the steps above. If connected, the Wi-Fi light on the control panel is normally on. Press and hold this button for more than 2s to disconnect from Wi-Fi network (Wi-Fi light will be off).

06 Web server

You can manage printer setup via the embedded Web server.

The screenshot displays the embedded Web server interface for a Pantum printer. The top navigation bar includes 'Product Information', 'Settings' (highlighted), 'User Management', and 'Log out'. A language dropdown menu is set to 'English'. The left sidebar shows a tree view under 'Settings' with 'Network settings' expanded to 'Protocol Settings', where 'Wired IP Configuration' is selected. The main content area is titled 'Wired IP Configuration' and contains the following fields:

Host Name	<input type="text" value="Pantum-363B08"/>
MAC Address	AC:C5:1B:36:3B:08
IPv4 Address Assignment Mode	<input type="text" value="Automatic"/>
IPv4 Address	<input type="text" value="10.10.132.170"/>
Subnet Mask	<input type="text" value="255.255.255.0"/>
Gateway Address	<input type="text" value="10.10.132.254"/>
Domain Name	<input type="text"/>
IPv4DNS Address Assignment Mode	<input type="text" value="Automatic"/>
Primary IPv4DNS Server Address	<input type="text" value="10.10.131.1"/>
Secondary IPv4DNS Server Address	<input type="text" value="0.0.0.0"/>
IPv6 Local Link Address	fe80::aec5:1bff:fe36:3b08

At the bottom of the configuration area are 'Apply' and 'Cancel' buttons. A 'Tip' box on the right states: 'This page provides configuration related to Printer Name, wired IPv4, and wired IPv6-related attributes.'

Visit the embedded Web server

1. Turn on the power of printer and computer.
2. Connect the printer to network to ensure that the printer is connected to the network where the computer is connected to
3. Input the IP address of printer in the address bar of Web browser to visit the Web server imbedded in printer.

View the IP address of printer via control panel or print the "NetConf Pg" out to view the IP Address of printer.

4. Click "Log in" option, input user name and password (the default user name is admin and the initial password is 000000) and click "Log in".





Note: • For safety reasons, you are suggested to change the default password, which can be finished in the "User Management" interface.

- The printer supports WPA2-Enterprise network configuration, which can enhance the network information security of the printer.

07 Print

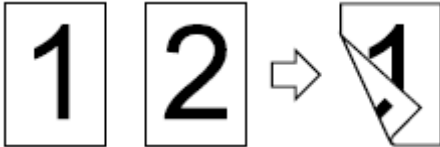
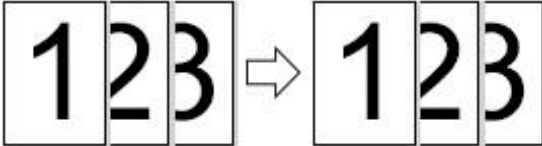
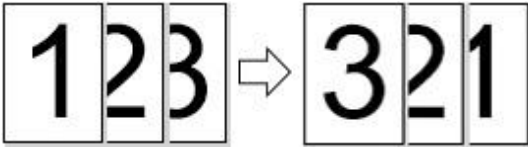
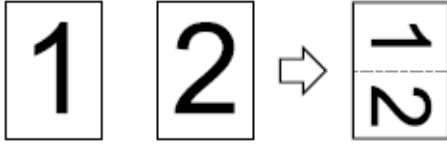
Print Function

You can set the print function through "Start"->"Devices and Printers"- select corresponding printer- right click – set print function in "Printing preferences". Some functions are as follows:

Functions	Diagram
Automatic Two-Sided Printing	
Collate Print	
Reverse Print	
N-in-1	
Poster Print(for Windows Operation System only)	
Zoom Print	
Booklet printing	
Custom Size	

Note: • You can realize poster printing feature by selecting 2x2 poster printing in multipage.

• You can enable Printing Preferences and click the Help button to view detailed function description. Please refer to [“Open Help Document”](#) for the method to open help document.

Print Settings

Setting the printing parameters

Before sending a print job, you can set the printing parameters in the following two ways.

Operating system	Temporary printing setup change	Permanent default setup change
Windows 7	1. Click “File” menu – “Print” – “Select printer” - “Printer properties” (the detailed steps may differ because of multiple operating systems).	1. Click “Start” menu- “Control Panel” – “Devices and Printers”. 2. Right click on the printer icon, select “Printing preference” and then change setup and save it.
macOS	1. Click “File” menu – “Print”. 2. Change setup in the window popping out.	1. Click “File” menu – “Print”. 2. Change setup in the window popping out and click to save the preset. (Select preset every time before printing, or print according to default setup.)

Note: • Priority of App setup is senior to printer setup.

Automatic Two-Sided Printing

The printer supports automatic two-sided printing of plain paper. Paper size supported by the automatic two-sided printing: A4, Letter, Legal, Oficio, Folio.

Note: • Trying the automatic two-sided printing may damage the printer if some paper media are not suitable for automatic two-sided printing.

- Auto duplex printing does not support poster printing.
- Please refer to [Chapter 2](#) for paper loading and type of mediums that can be printed via auto feed tray.

Duplex printing unit setup

For the purpose of achieving the best printing result, you can set up the paper size of duplex printing unit. As for duplex printing of A4 papers, the slide should be adjusted to the A4 position; as for Letter, Legal, Folio and Oficio duplex printing, the slide should be adjusted to the Letter position. Setup steps of duplex unit are:

1. Draw out duplex unit.



2. Make the backside of duplex unit up.



3. Adjust paper size slide to A4 or Letter position to finish setting up.

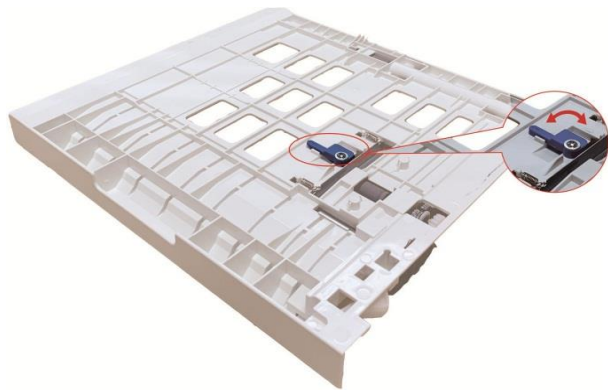

4. Install the duplex unit in the printer.



How to carry out auto duplex printing

1. Open the print job to be printed from the application (such as a Notepad).
2. Select Print from the File menu.
3. Select printer of the corresponding model.
4. Single click "Preferences" for printing setup.
6. Single click "OK" to finish printing setup. Click "Print" to realize auto duplex printing.

Mute Printing

If the Mute Printing is set, the printing noise will be reduced but the printing will slow down to some extent.

The operating steps of mute printing are as follows (applicable to printers that are installed via USB connection)

Windows 7 is taken as the example in the following operation. The information on your computer screen may differ because of multiple operating systems.

1. Enter the "Start menu" – "Control Panel" –view "Devices and Printers".
2. Right click printer and select "Printer properties" in the pull-down menu.
3. Enter the "Secondary Settings" option.
4. Tick "Mute printing" and click "Ok" to finish setup.

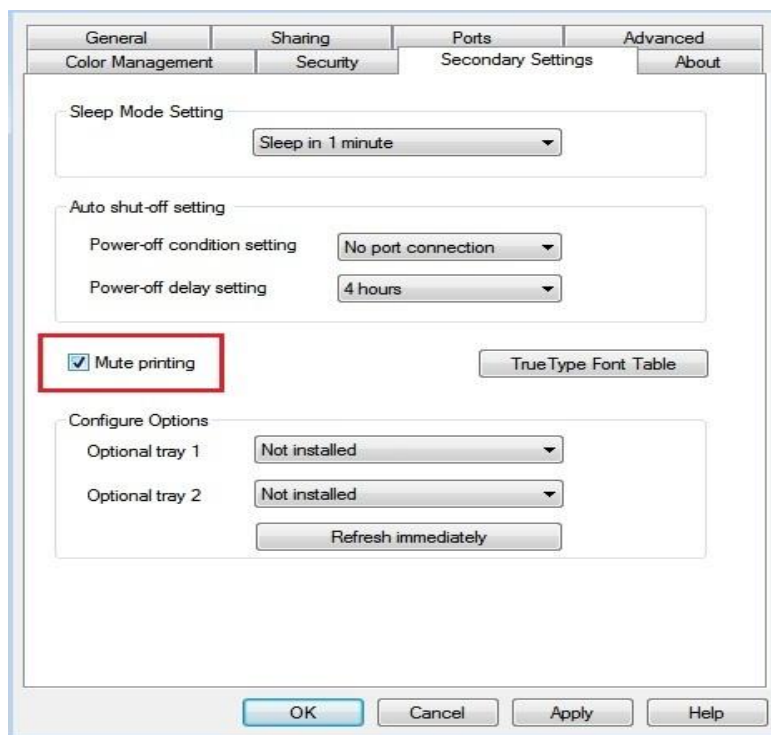

5. Open the printing work from the App, select a printer of the corresponding model and then set up printing according to needs.
6. Click "Print" to realize mute printing.

Note: • You may also set mute printing directly with the keys on control panel. For specific steps, please refer to ["Mute Printing"](#).

Auto shut-off setting

“Auto shut-off setting” to set off condition and off delay of printer.

1. Enter computer “Start Menu” – “Control Panel” – View “Devices and Printers”.
2. Right click printer, select “Printer properties” in drop-down list.
3. Enter “Secondary Settings” option and set “Auto shu-off setting”.
4. Click “OK” to finish setting.

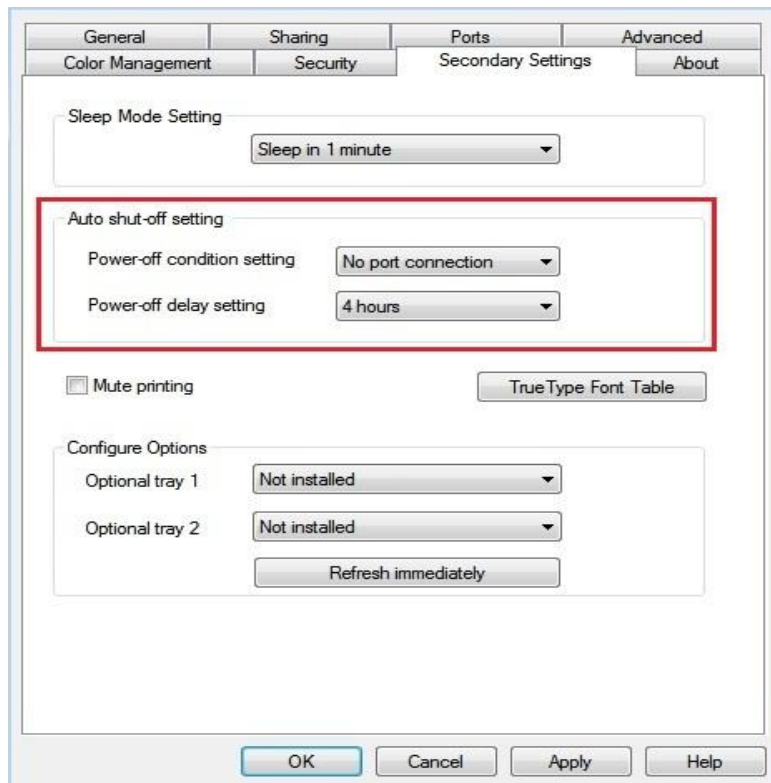

- Note:** • For printer provided with LCD control panel, users may set auto off function through control panel keys. Please refer to [Chapter 11](#).
- Individual countries (or regions) do not support auto off setting.

08 Copying

Copying function

Copy		Instructions
Common copying	Original Size	Set the paper size of the originals.
	Copy To	Set the paper size and type of the specified tray.
	Multipage	Print a multi-page document to a piece of paper.
	Clone	Print several identical images to a piece of paper.
	Poster	Print a one-page original to pieces of paper.
	Collated copy	Collate copies of an original.
	Duplex copying	It supports manual duplex copying for originals.
	Image quality	Set the definition mode to improve the copying effect.
	Intensity	Adjust deep-light copying effect by setting intensity.
	Resizing	Reduce or enlarge the size of image copied.
ID card copying	Arrangement mode	Set the arrangement mode of ID card to be copied.
	Paper Size	Set the paper size.
	Intensity	Adjust deep-light copying effect by setting intensity.
Receipt copying	Intensity	Adjust deep-light copying effect by setting intensity.
	Paper Size	Set the paper size.

Common copying setting

Change relevant setting with "copying setting menu" for better copying effect.

1. Press "Copy" and then "Menu" on control panel to enter the "Menu Setting" interface.
2. Press "OK" to enter the "Copy Setting" interface.
3. Press "▲" or "▼" to select option to be set and press "OK" key to set option.

Note: • The image quality, intensity, resizing and paper setting can keep valid after options are set.

• Settings on all-in-one, clone, poster, collated copy and duplex copy will be restored to defaults after completing the copying, switching among panel keys or rebooting the machine.

Multipage

With setting on all-in-one feature, a 2- or 4-page document could be copied to one piece of paper. Copying with the ADF and the glass platen are both supported.

The multipage includes 3 modes:

(1) Two-in-one:

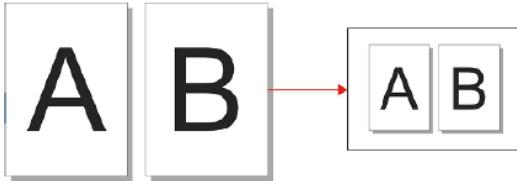

(2) Horizontal four-in-one:



(3) vertical four-in-one:



Note: "Multipage" and "resizing function" cannot be set at the same time.

Collated copy

The "Collated Copies" feature supports only copying with the automatic document feeder (ADF).

The collated copy includes 2 modes:

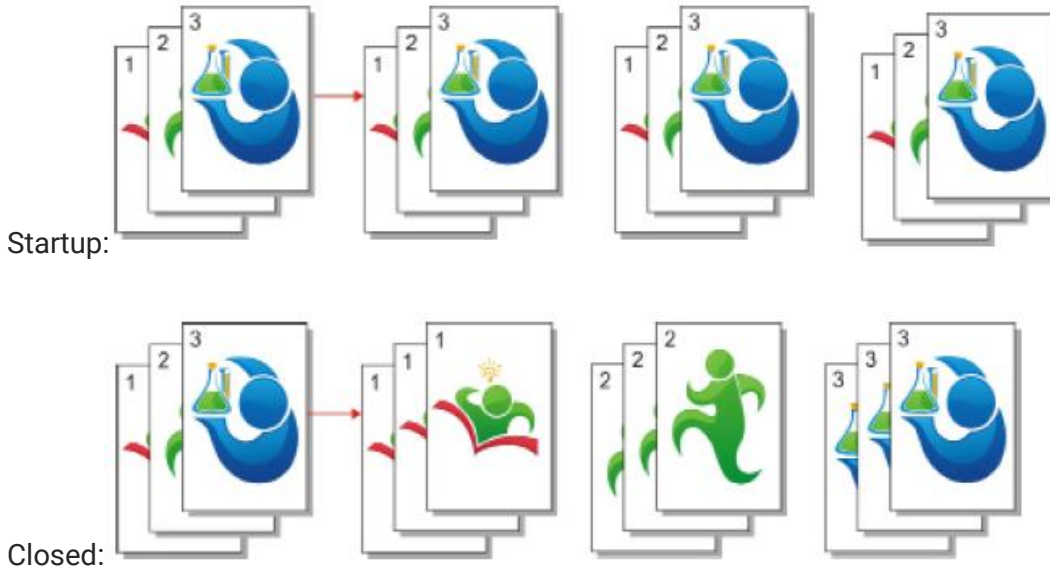

Duplex copy

You can use flat plate and ADF for Auto Duplex copy, ADF supports auto duplex copy.

There are 4 modes in total for duplex copying:

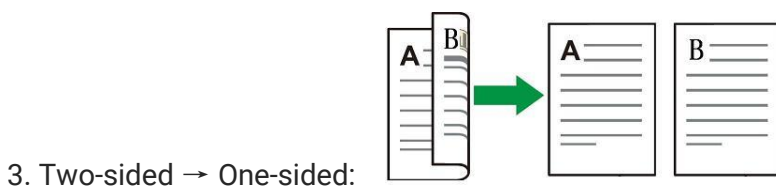
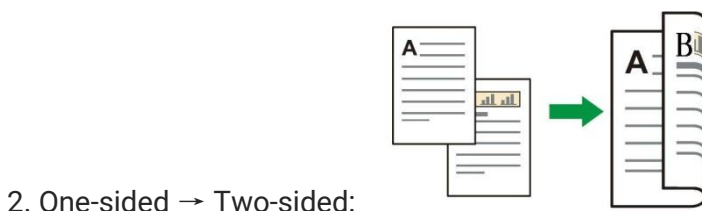
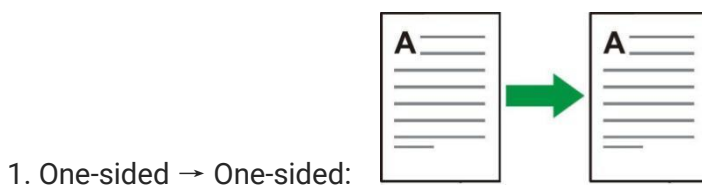

4. Two-sided → Two-sided:

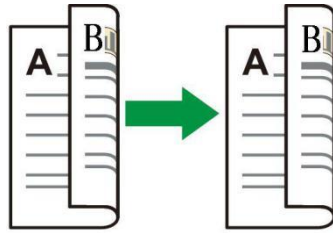

ID card copying setting

For better copying effect, you can enter the "ID Card Copy Settings" menu to change relevant settings.

1. Press "ID Card Copy" and then "Menu" on control panel to enter the "Menu Settings" interface.
2. Press "OK" to enter the "ID Card Copy Settings" interface.
3. Press "▲" or "▼" to select option to be set and press "OK" key to set option.

Receipt setting

For better copying effect of bills, you can enter the "Bill Copy Setting" menu to change relevant settings.

1. Press "Bill Copy" and then "Menu" on control panel to enter the "Menu Settings" interface.
2. Press "OK" to enter the "Bill Copy Setting" interface.
3. Press "▲" or "▼" to select option to be set and press "OK" key to set option.

09 Scan

This printer provides two types of scan: "Push Scan", which means scanning through the printer's Control Panel operations; "Pull Scan" which means scanning through PC terminal scanning the application. Before scanning, please be sure a printer driver has been installed in the computer.

Pull Scan

You may scan with the scanning application in PC via USB, wired or wireless connection. Please be sure the printer has been properly connected before scanning.

Windows system scan

Pantum Scan Application

Operation Steps:

1. Double click on "Pantum Scan Application" on the computer, the icon is shown as below: 2. The prompt window is shown as below:

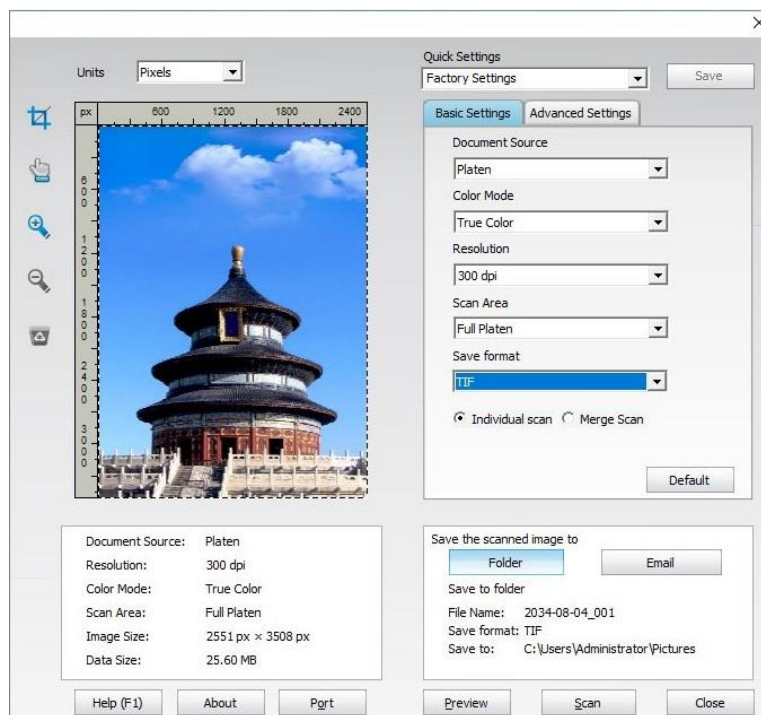

3. Set Scan in the right list. Click "Scan" on the bottom right corner and start scan.

Note: • Images in the format of BMP, JPG, TIF, PDF, PNG, and OFD can be scanned by the Pantum scanning application software. The image text recognition is available for documents in the format of DOCX, XLS, XLSX, PPTX, TXT and searchable PDF. (If you need to use the image text recognition function, please download and install the OCR software according to the interface prompts after the driver installation. For the installation method, please refer to [Section 3](#))

macOS System Scan

ICA Scan

Open ICA via "Print and Scan"

Operation Steps:

1. After installing the printer driver, click "System Preferences" icon on the bottom left corner of the computer desktop.
2. After the window pops up, click on "Print and Scan".
3. After the window pops up, click on "Scan".
4. Click on "Open Scanner" and the scan window will pop up.
5. Click on "Show Details" on the bottom right corner to set the scan parameters.
6. Click on "Scan" on the bottom right corner and start scan.

Call ICA through applications

Operation Steps:

1. Click on "Finder" icon on the bottom left corner of the computer desktop. Find "Image Capture" in "Applications" and click to launch the application.
2. After selecting the printer in the left list, set the scan parameters in the right list. Click on "Scan" on the bottom right corner and start scan.

TWAIN Scan

Take Photoshop as an example.

Operation Steps:

1. Launch Photoshop, click on "File" – "Import" on the top left corner and select TWAIN Scan, as is shown below:
2. After the window pops up, set the scan information in the right list of "Basic Setting" and "Advanced Setting". Click on "Scan" and start scan.

Push Scan

This section is mainly to introduce how to scan files to PC, E-mail, FTP, SMB and USB flash disk with the printer control panel.

Note: • Scan to PC, Email, FTP, SMB and USB flash disk, save as PDF, TIFF, JPEG or OFD.

Scan to PC

You may operate the printer's control panel to scan a file to PC. (Only support connection method of USB connection line.)

1. Be sure the printer and the computer are both switched on and connected with each other properly.
2. Put an original on the glass platen or into the ADF (please see [Chapter 2](#) for how to put an original).
3. Press "Scan" on the control panel to enter the scanning interface.
4. Select scanning parameters according to your needs, then press "Start" to start scanning.

Scan to E-mail

You may scan a black-white or color file as an appendix to the e-mail application, with specific operation steps as follow:

1. Be sure the printer and the computer are both switched on and connected with each other properly.
2. configure the SMTP Client.
3. configure the e-mail address book.
4. Put an original on the glass platen or into the ADF.
5. Click "Scan-Scan to Email" in printer control panel.
6. Select proper scan setting, click "Scan" button to make a scan.

Please follow these instructions on the settings for group emails:

Set the group name for group e-mail sending by webpage, and set the members, i.e.the receivers, in the group of group email. After finishing scanning, firmware will send the scanned documents to the mail server. Then mail server sends the documents to every member of the group.

Scan to FTP

Be sure the user is in an Internet-connected environment in scanning files to FTP server. If you want to scan large files, you may need to input the server address, user name and password to log in the server, with specific operation steps as below:

1. Be sure the printer and the computer are both switched on and connected with each other properly.
2. configure the FTP address book.
3. Put an original on the glass platen or into the ADF
4. Click "Scan-Scan to FTP" in printer control panel.
5. Select proper scan setting, click "Scan" button to make a scan.

Scan to U disk

This printer supports scanning files to USB without a computer. Before operation, please make sure the USB has enough storage space. The specific operation steps are as follow:

1. Insert the USB into the printer's front USB interface.
2. Put an original on the glass platen or into the ADF.
3. Click "Scan-Scan USB" in printer control panel.
4. Select proper scan setting, click "Scan" button to make a scan.

The printer will create a folder named PantumScan in which all scanned files are saved in PDF or JPG.

Note: • USB formats supported: FAT and FAT32 for Windows system and MS-DOS (FAT) for macOS system.

Scan to SMB

To use "Scan to SMB" function, you need to create a shared folder on the Windows or Mac computer first.

Create a shared folder

Windows 7 is taken as example for description of the following steps.

1. Right click the folder under Windows system you want to share, and select Properties.

2. Select the "Share" tab, and click "Share".

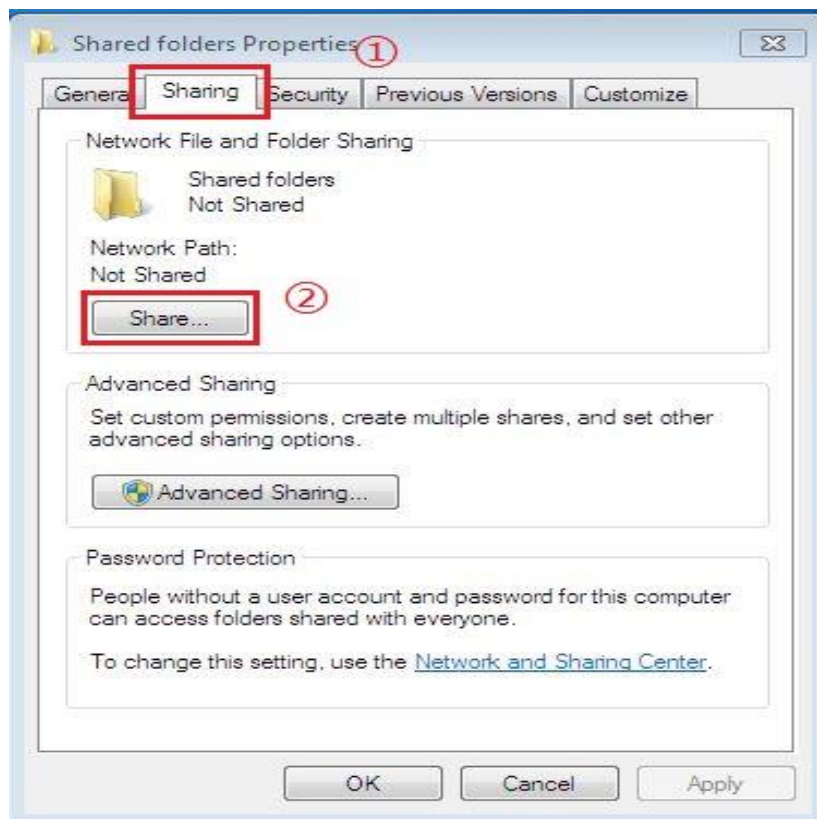

3. In the pop-up "Network Access" window, click the drop-down menu, select "Everyone", and click "Add".

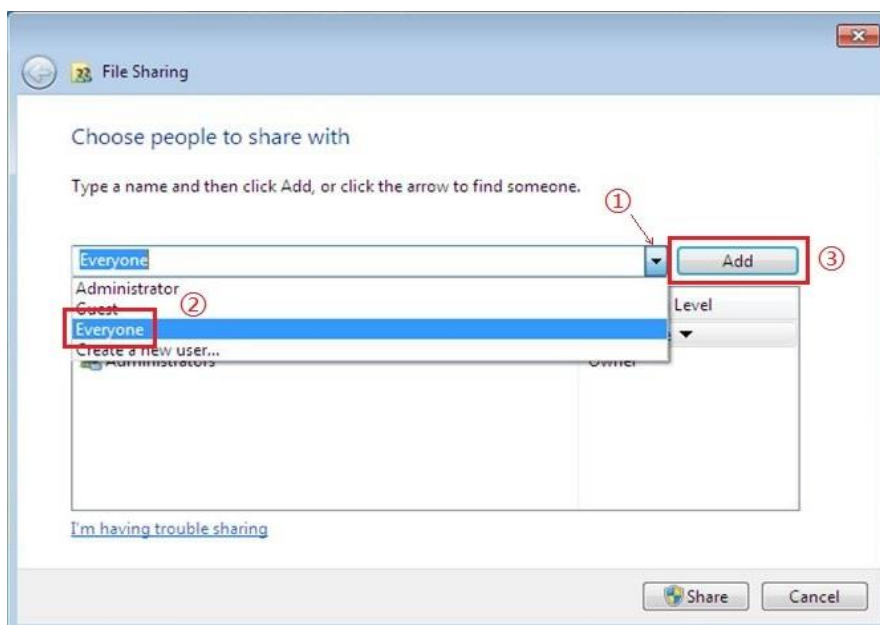

4. Change the “Everyone” permission level added in Step (3) to “Read/Write”, and click “Share (H)” in the lower right corner.

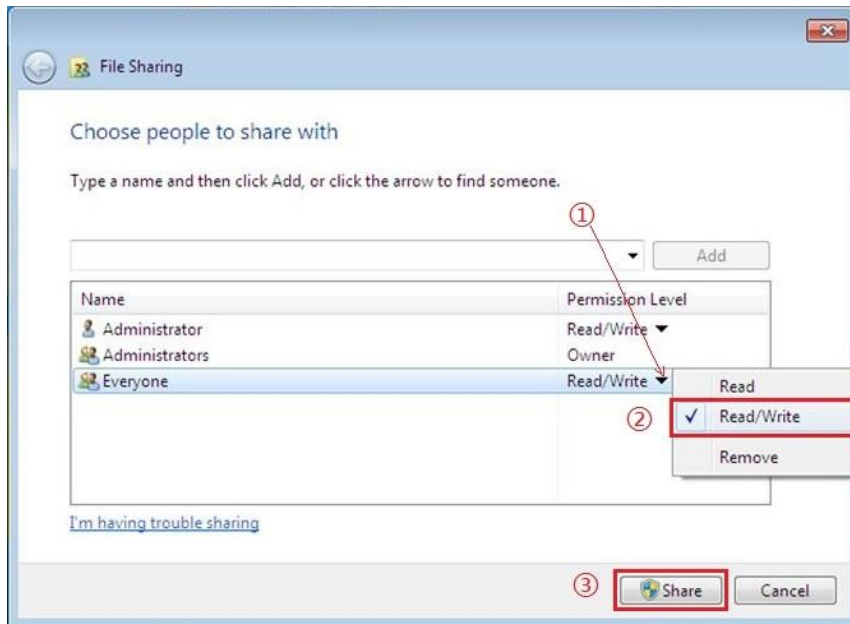

5. If your shared folder path is displayed at the network path, it means it is successfully shared.

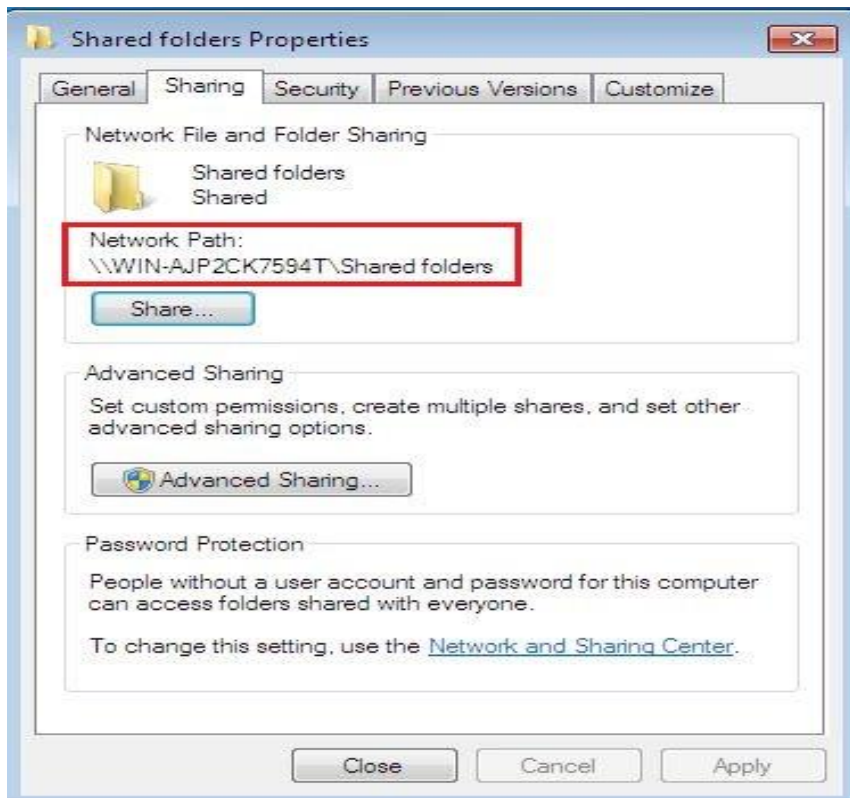

“Scan to SMB” configuration

1. Be sure the printer and the computer are both switched on and connected with each other properly.
2. To configure SMB address book.
3. Put an original on the glass platen or into the ADF.
4. Click “Scan - Scan to SMB” on printer control panel.
5. Select proper scan setting, click “Scan” button to make a scan.

10 Routine Maintenance

Note: • Printer appearance may differ because of various models and functions, so the schematic diagram is only for your reference.

Cleaning the Printer

Note: • Please use mild detergents.

• Some parts of the printer are still in high temperature within a short time after use. To prevent burns, please don't directly touch places labeled with high temperature warning in contact with internal components after opening the printer's front or rear cover.

1. Use a soft cloth to wipe the outside of the printer clean.



2. Lift the scanner cover, and gently wipe the glass platen and automatic duplex document feeder CIS (D-CIS) with soft cloth.



3. Open the front cover and take the laser toner cartridge out along the track.

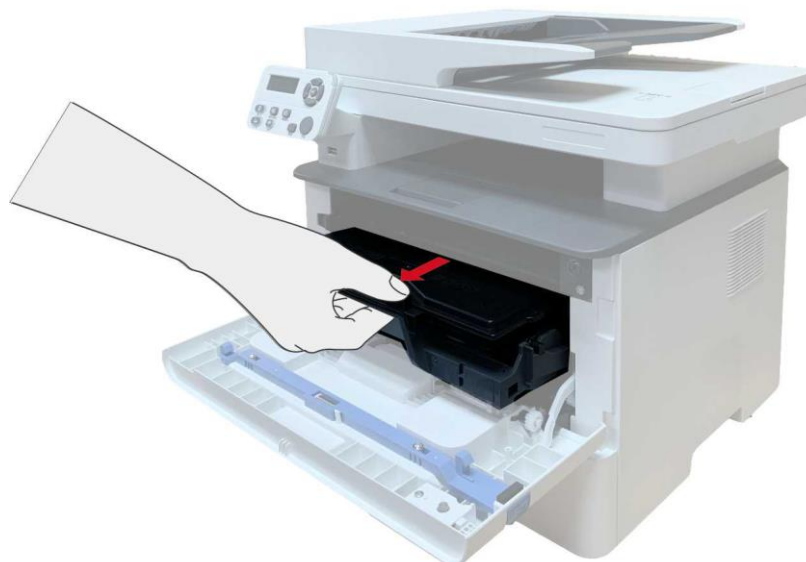

Note: • When removing the toner cartridge, put the toner cartridge in a protective bag or wrap it with thick paper to avoid direct light damaging the toner cartridge.

4. Clean the inside of the printer by gently wiping the shaded area, as shown in picture, with adry and lint-free cloth.



5. Wipe the LSU lens of printer gently with dry lint cloth.

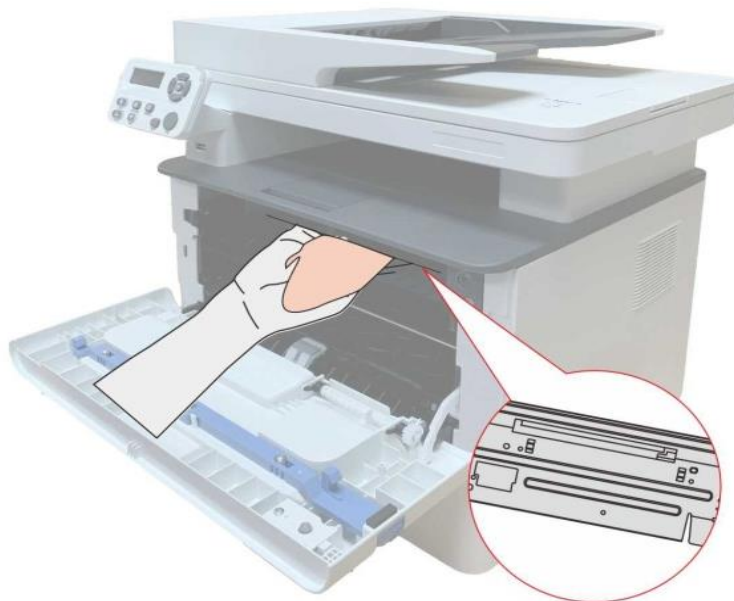

6. Open the auto feed tray and wipe the pickup roller gently with dry lint cloth.

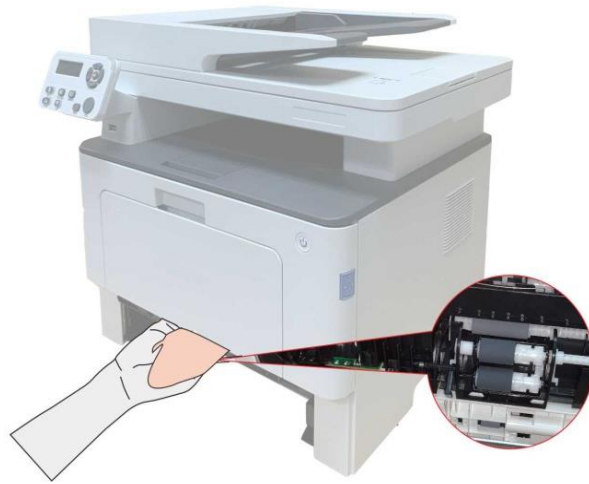

Note: • The machine with the ADF should be regularly cleaned, removing dirt on the top cover of the ADF. Please wipe the place as shown in figure with a soft cloth.



Toner cartridge and drum component maintenance

About toner cartridge and drum component component

1. Cartridge, use and maintenance of the drum assembly.

Please use the original toner cartridge for better printing quality.

Please pay attention to the following items while using the toner cartridge:

- Please keep the toner cartridge in a dry and dark place.
- Do not refill the toner cartridge without permission; otherwise, the damages caused will not be included in the scope of warranty of the printer.
- Please place the toner cartridge in cool and dry places.
- Please do not place the toner cartridge near ignition sources, as the toner inside it is inflammable and may cause fire.
- Please pay attention to toner leakage while it is taking out or disassembled. In case of toner leakage, skin contact with toner or spattering into eyes or mouth, please wash it with clear water immediately, or see a doctor if feeling unwell.
- When placing the cartridge, please stay away from children may contact area.

2. Service life of toner cartridge

- The service life of toner cartridge is depending on the toner quantity needed by printing.
- When a prompt that "The Toner Cartridge life Expired" appears on the display, it indicates its service life expires. So please replace it.

3. Service life of drum component

- When a prompt that "The Drum Unit life Expired" appears on the display, it indicates its service life expires. So please replace it.

Replace toner cartridge and drum component

Note: Please pay attention to the following matters before replacing toner cartridge:

- Since there may be toner on the surface of toner cartridge, please pay attention while taking it out to avoid spattering.
- Please place the toner cartridge taken out on paper to avoid large-scale spattering of toner.
- When installing, do not touch the surface of the toner cartridge, so as to avoid scratching it.

Toner cartridge replacement steps:

1. Power off the printer.



2. Open the front cover and then remove the laser toner cartridge along the guide rail.

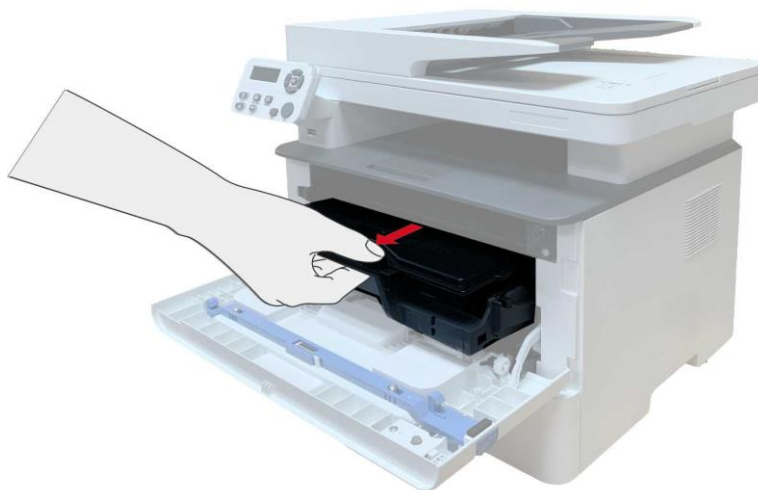

3. Press the blue button on the left side of drum component with left hand and lift the toner cartridge handle with right hand at the same time to take the toner cartridge out.

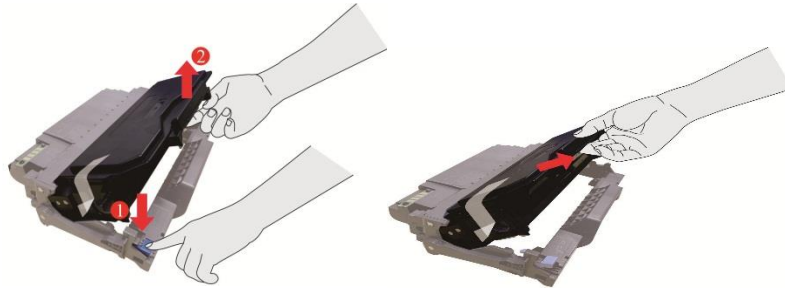

4. Open the package of the new toner cartridge and hold the toner cartridge handle to shake it left and right for 5 – 6 times, so that the toner inside can be uniformly dispersed.

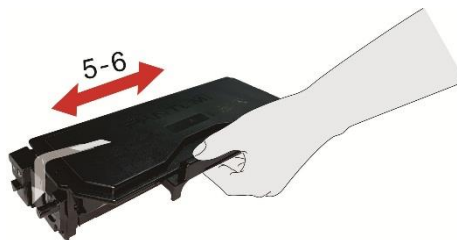

5. Pull the seal out and take the toner protection cover out.



6. Install the drum component along the inner track to finish installing toner cartridge.

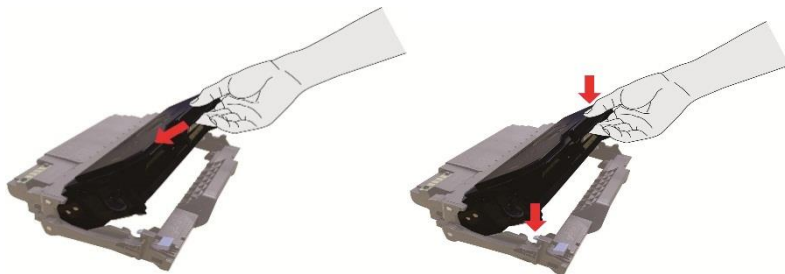

7. Take the drum component with toner cartridge installed and install it inside the printer along the inner track of printer to finish installing.

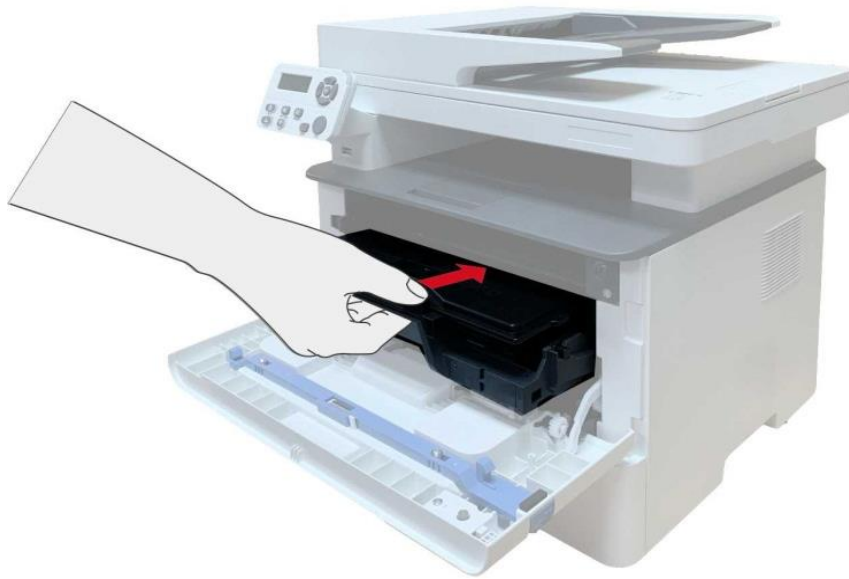

8. Close the front cover.

Replace the drum assembly steps are as follows:

1. Power off the printer.



2. Open the front cover and take the laser toner cartridge out along the track.

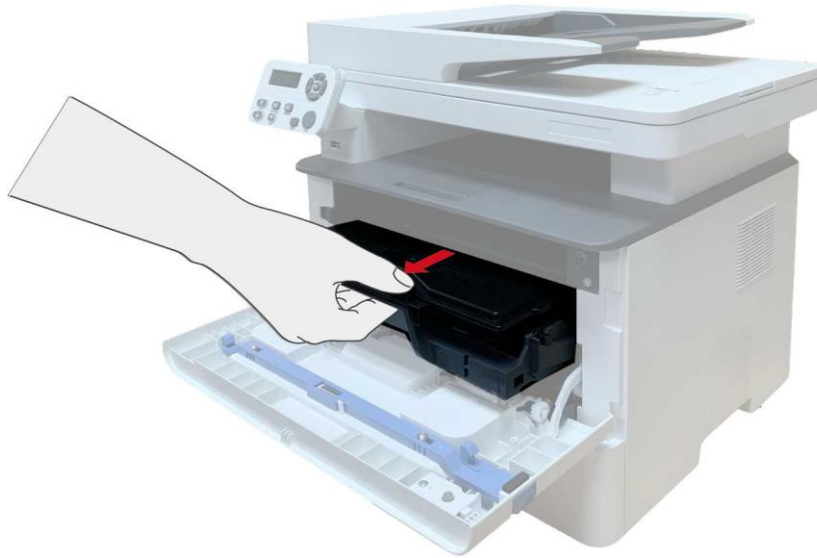

3. Press the blue button on the left side of drum component with left hand and lift the toner cartridge handle with right hand at the same time to take the toner cartridge out.

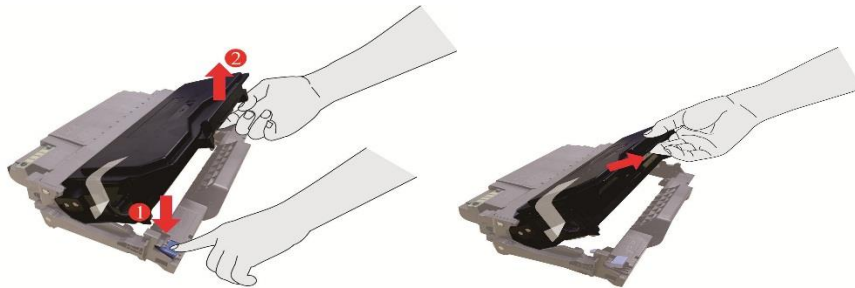

4. Open the package of new drum component, take the protection device of drum component, and put the drum component on a horizontal table.

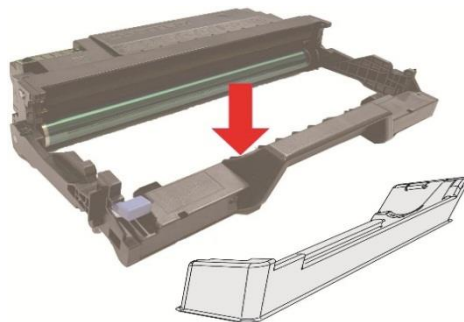

5. Install the drum component along the inner track to finish installing toner cartridge.

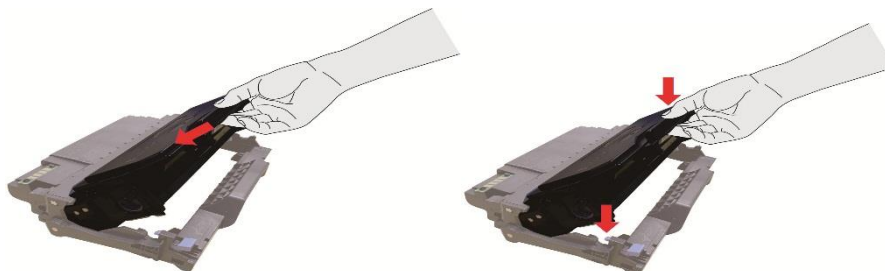

6. Take the drum component with toner cartridge installed and install it inside the printer along the inner track of printer to finish installing.

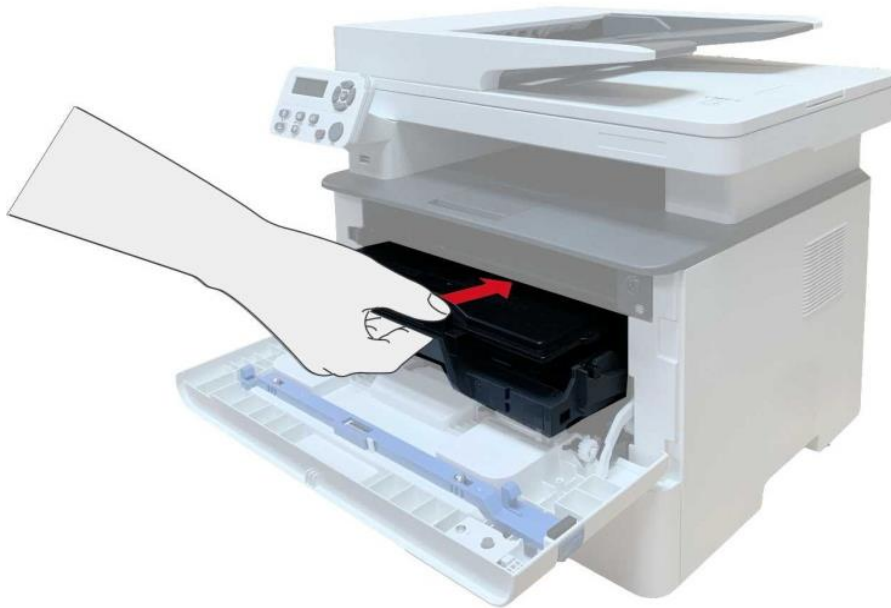

7. Close the front cover.

Installing and removing the optional tray

Installing optional tray

This printer supports the use of optional trays, and can hold up to 2 optional trays. Each tray can hold up to 550 pieces of 80g/m² paper. If you want to buy optional trays, please contact the local dealer who has purchased the printer.

1. Turn off the printer.



2. Unplug the power cord from the electrical outlet, and then unplug the power cord from the printer.
3. Unpack the optional tray, and then remove all packaging materials.
4. Make sure the printer body and optional trays are placed correctly, as shown in the figure below.



5. Plug the power cord into the printer and turn on the power.
After installing the optional tray, you need to update the printer status again (For how to update the printer status, see [“Updating the optional tray status”](#)).

- Note:**
- For precautions on loading paper, see [“Paper and Print Media”](#).
 - For the type of media to be printed with the optional tray, see the [“Paper Specification”](#).
 - For the installation of optional trays, please refer to the Installation Guide supplied with the optional trays.

Removing the optional tray

1. Turn off the printer.



2. Unplug the power cord from the electrical outlet, and then unplug the power cord from the printer.
3. Lift the printer body with both hands and remove the optional trays.



After removing the optional tray, you need to update the printer status again

Updating the optional tray status

Each time you install/remove the optional trays, you need to manually update the printer driver status. Take Windows 7 as an example for this section.

1. Install the printer driver.
2. Enter the "Start menu" - "Control panel" - view "Device and Printer".
3. Right-click the printer icon and select "Printer Properties" in the pull-down menu.
4. Enter the "Auxiliary Settings" option. to set the corresponding configuration options.
5. Click "Refresh Now-Check Printer" - "OK/Apply" to update the printer status.

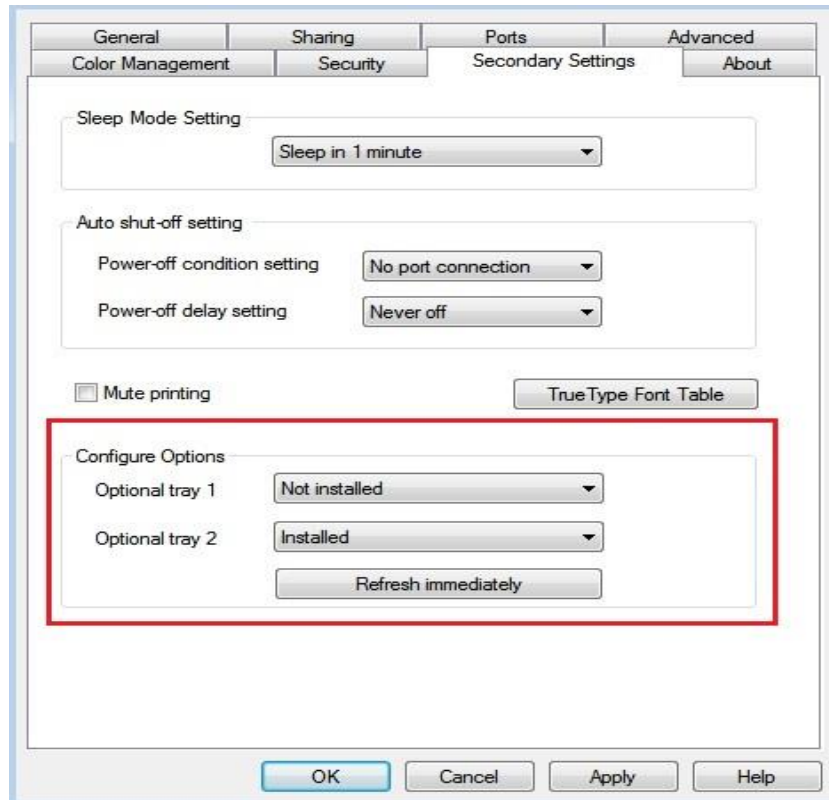

11 Troubleshooting

Please read this section carefully. It may help you to solve common problems encountered during the printing process. If the problems persist, please contact Pantum Aftersales Service Centre.

Prior to handling common problems, first check that:

- The power cord is connected correctly and the printer is powered on.
- All of the protective parts are removed.
- The toner cartridge is installed correctly.
- The paper is correctly loaded into the tray.
- The interface cable between the printer and the computer is connected correctly.
- The correct printer driver has been selected and installed properly.

Cleaning Jammed Paper

Middle jam

Note: • When removing the paper jam, please don't touch immediately places labled with high temperature warning in contact with internal components after opening the printer's front or rear cover, to prevent burns.

1. Pull paper tray out.

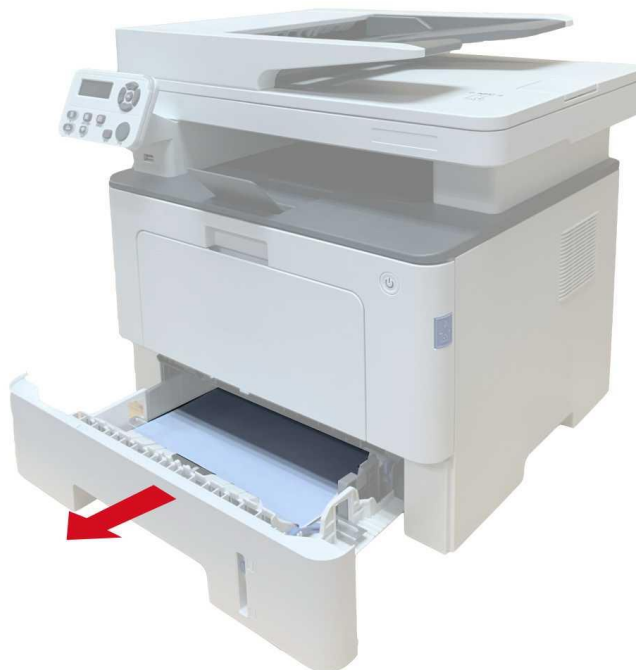

2. Gently pull the jammed paper out.

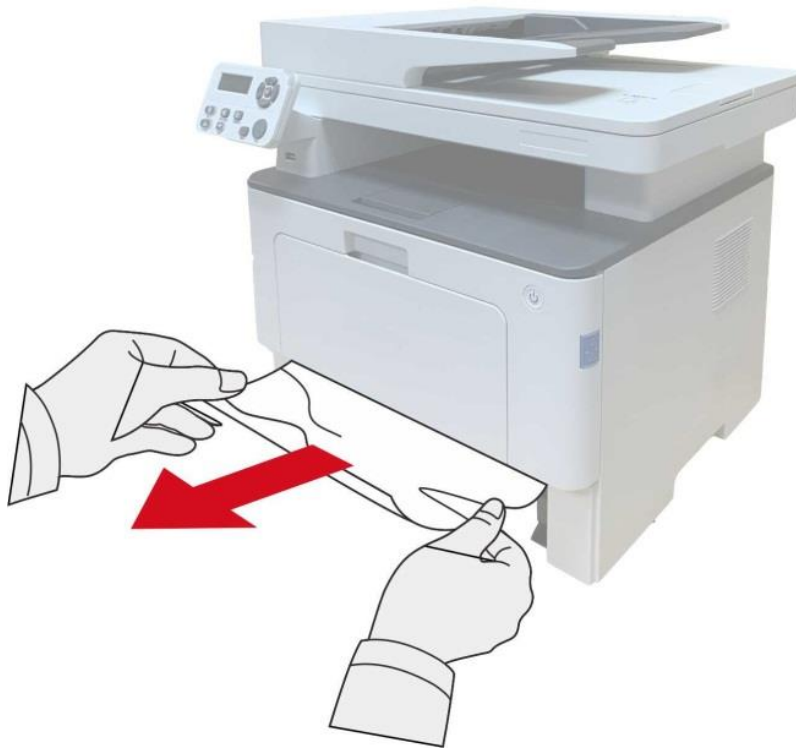

3. Install paper tray.

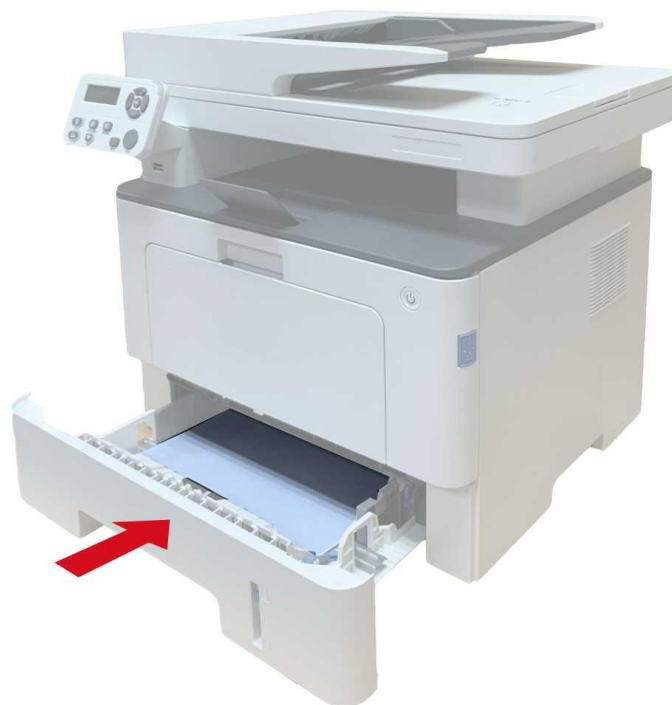

4. Open the front cover.



5. Take the laser toner cartridge out along the track. (For the purpose of preventing printing quality from affecting by the exposure of photosensitive drum, please put the laser toner cartridge inside the protection bag or wrap it with thick paper).

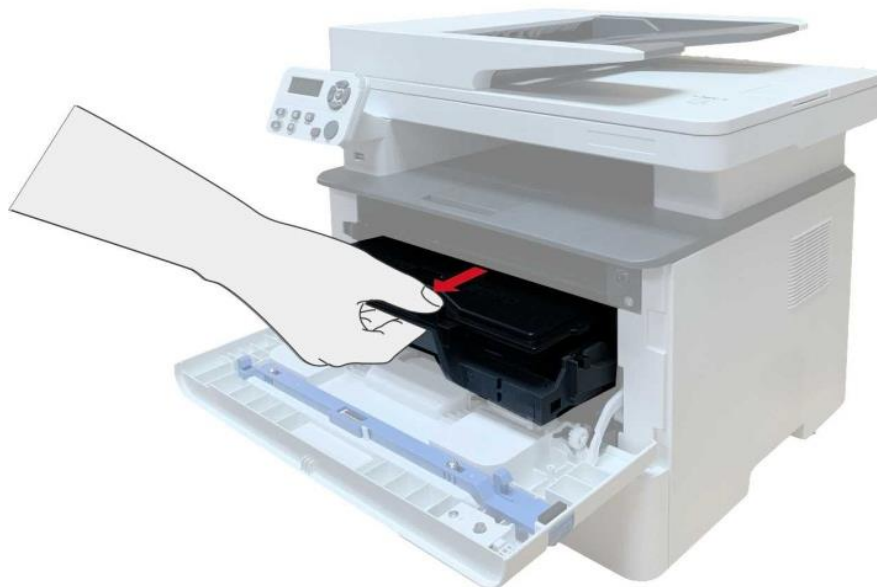

6. Gently pull the jammed paper out.

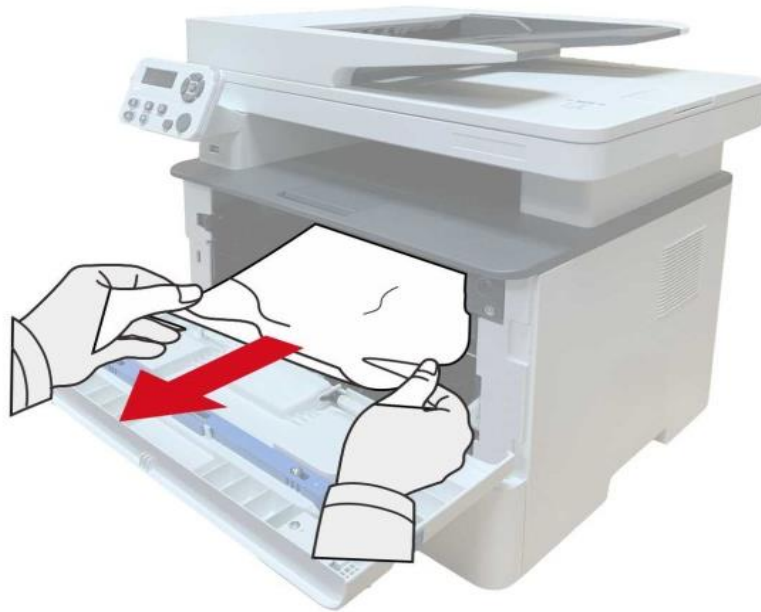

7. After taking out papers jammed, install the laser toner cartridge again and close the front cover, then the printer will recover printing.

Paper Jam in the Fuser Unit

Note: When papers jammed in fuser unit are taken out, please pay attention and do not touch the shaded area shown below in order to avoid burns.

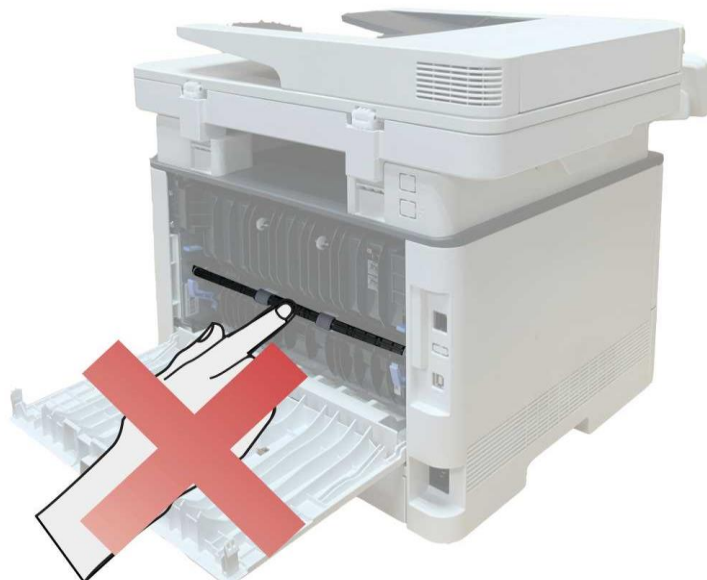

1. Open the front cover and then remove the laser toner cartridge along the guide rail.

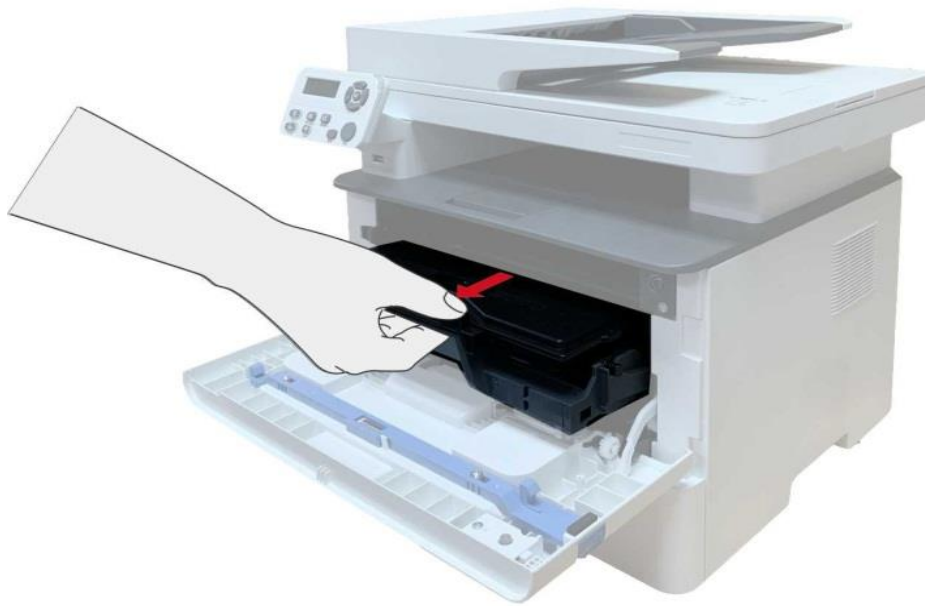

2. Open the rear cover.



3. Open the fuser door using the handles on both sides.



4. Gently pull the jammed paper out.



5. Close the back cover after removing the paper jammed.



6. Install a new toner cartridge and then close the front cover; then, the printer will recover printing automatically.

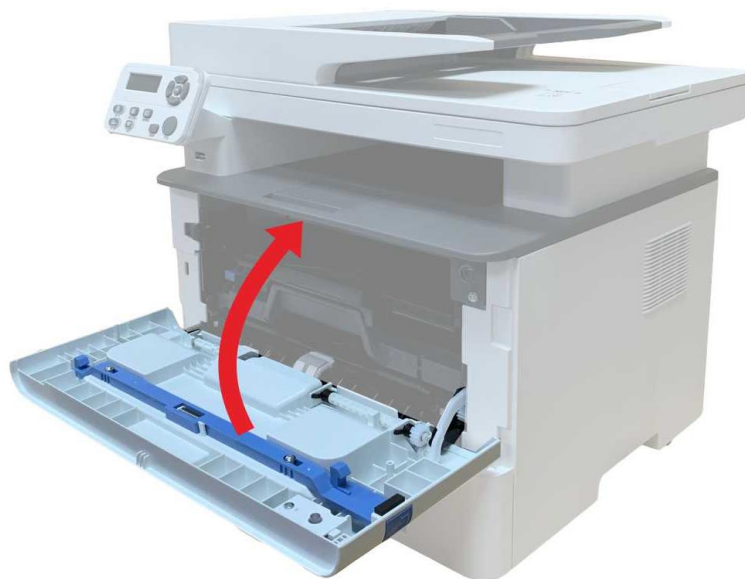

Duplex Unit Jam

1. Remove the duplex printing unit from the back of the printer.



2. Remove the jammed paper from the duplex unit.

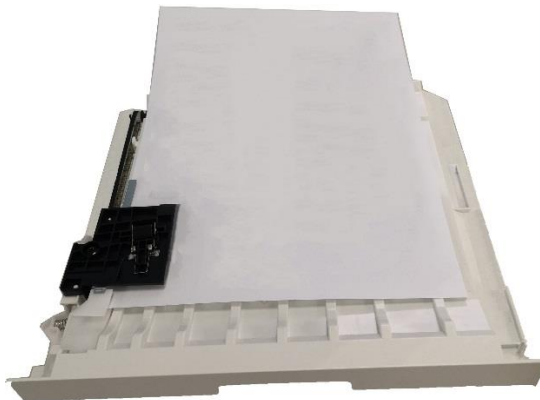

3.If the paper does not come out along with the duplex unit, open the tray and remove the jammed paper directly from the bottom.

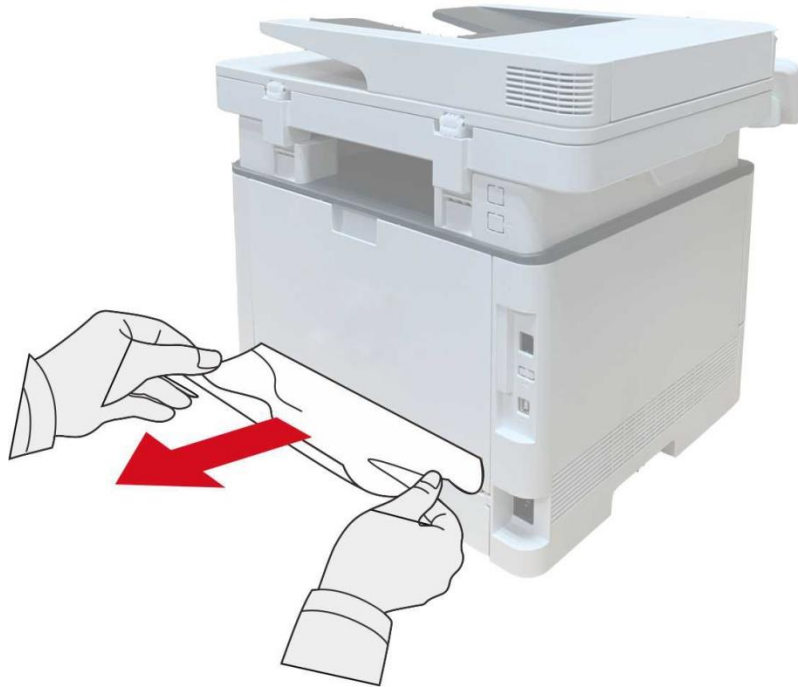

4. After taking papers jammed out, install the duplex unit back and inspect other parts to the product. If it can be ensured that there are no jammed papers, open and close the front cover and then the printer will recover printing automatically.

Note:After all papers jammed are taken out according to the above steps, close the front cover and tidy the papers in paper tray, then the printer will recover to print automatically.

- If the printer still does not start printing, please check that all the jammed paper inside the printer has been cleared.
- If you cannot remove the jammed paper yourself, please contact your local Pantum authorized repair center or send the printer to the nearest Pantum authorized service center for repair.
- Printer appearance may differ because of various models and functions, so the schematic diagram is only for your reference.

A paper jam occurs on the automatic document feeder (ADF)

1. Open the ADF's top cover.



2. Remove the paper jammed from the ADF.



3. After removing the paper jammed, close the top cover and then the printer will be back to the ready state.



4. If it is difficult to remove the paper jammed, please try to open the scanner cover and remove it from the pressing block.



Paper jam of auto feed tray

1. Pull out the automatic tray.



2. Gently pull the jammed paper out.



3. After removing the jammed paper, reinsert the automatic tray into the printer; press the front cover button to open and close the front cover, and the printer will resume printing automatically.

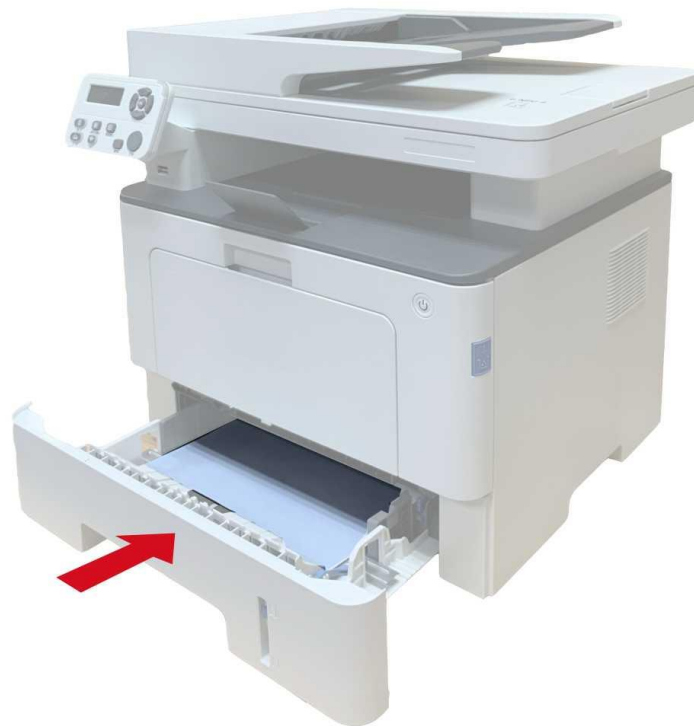

Paper jam of multi-purpose tray

1. Gently pull the jammed paper out.



2. After removing the jammed paper, reload paper into the multi-purpose tray; press the front cover button to open and close the front cover, and the printer will resume printing.



Paper jam of optional tray

1. Pull out the optional tray.



2. Gently pull out the jammed paper.



3. After removing the jammed paper, reinsert the optional tray into the printer, and the printer will resume printing automatically.



If paper cannot be seen in this area, stop and go to the next step:

1. Pull out the automatic tray.



2. Remove the jammed paper from the automatic tray.



3. After removing the jammed paper, reinsert the automatic tray into the printer, and the printer will resume printing automatically.



Software Failure

Problem	Solution
The printer icon does not appear in the "Devices and Printers" folder.	Reinstall the printer driver. Ensure that the USB interface cable and the
The printer is in Ready mode but it will not perform any print job.	If the failure still exists after restarting the Make sure the network cable of USB cable is connected correctly.
Failed to install the driver	Check whether the print spooler service is enabled. Check the power supply and the connection of the printer.
The driver cannot be used if the IP address of the printer has been changed	Modify the port IP address of the printer driver. If the above method does not work, please reinstall the printer driver. It is recommended that a fixed IP address should be set to the network printer. In the DHCP network, it is recommended to bind the IP address with the MAC address of the printer.

Error Message

Error Message	Cause	Measure
No Laser Toner Cartridge Detected	The laser toner cartridge is installed incorrectly or laser toner cartridge is damaged.	The laser toner cartridge is installed correctly or new laser toner cartridge is replaced.
Toner Low (this prompt is displayed together with the standby picture alternately.)	The toner in cartridge runs low.	Please replace with a new toner cartridge.
As the toner is low, it is not available to accept the printing job (this prompt is displayed together with the standby picture alternately.)	If the toner in cartridge runs low, the printing of fax job received cannot be executed. (Normal in fax sending, file printing, copying and scanning.)	Please replace with a new toner cartridge or find out the "Low in Toner, Continue to Print" option among the fax receiving setting options and then set it as "On" for continuous printing. (Note: once the printer detects that the toner in cartridge doesn't run low during booting or opening and closing its cover, it will set the "Low in Toner, Continue to Print" option enabled before by user back to "Off".)
Toner cartridge life expired.	The toner in cartridge runs out.	Please replace with a new toner cartridge.
Feed jam	The print paper is loaded incorrectly. The paper is outside of the specification range.	Please correctly load the print paper.
Printer paper jam	The print paper is loaded incorrectly.	Please correctly load the print paper.
Scanner is Busy	With other scan jobs.	Please cancel the current scan job or wait for the completion of other scan jobs.
Scan failed	Scanner internal failure.	Please contact Pantum Customer Service.
No paper in ADF	If you have selected ADF as the scan source, this message appears when you start a copy or scan job without loading paper in the ADF.	Please put in the original properly.

Paper jam occurred on ADF	This prompt appears when there is a feed jam or feed failure in copying or scanning with the ADF.	Please remove the paper jam, arrange well and put originals into the ADF for scanning again.
---------------------------	---	--

Note: • If the problem persists, please contact the customer service center. See the Three Guarantees certificate for contact details.

Common Troubleshooting





Common Trouble

Trouble Type	Fault phenomenon	Cause	Solution
Problems in printing	Poor print quality	See Image Defects.	See Image Defects.
	Failed to copy	The scanner is damaged.	Please contact Pantum Customer Service.
Problems in copying	Copy Image Abnormal	<ul style="list-style-type: none"> • The scanner is dirty or defective. • The toner cartridge is dirty or damaged. 	<ul style="list-style-type: none"> • Clean the scanner. • It is suggested to replace the original toner cartridge.
		<ul style="list-style-type: none"> • Power cord of the device is not properly connected. • The cable between the computer and the printer is not connected properly. • Error in specifying the print port. • The printer is offline and User Guide of Printer is checked. • The printer has not recovered from an internal error, such as a paper jam, paper empty, etc. • Driver program of printer is not installed correctly. • The LCD screen prompts error messages. 	<ul style="list-style-type: none"> • Ensure proper connection of the power cord. • Please disconnect the printer cable and then connect it again. • Please check printer settings of the Windows to make sure the printing job could be sent to the correct port. If the computer is equipped with several ports, please be sure to connect the printer to the correct port. • Please make sure the printer is online without any abnormality. • Please remove errors to make the printer return to normal. • Please uninstall and then reinstall the printer driver.
Problems with the Printer	The printer does not work		

	Online printing does not work	<ul style="list-style-type: none"> • The cable between the computer and the printer is not connected properly. • Driver program of printer is not installed correctly. • Printer internal failure. 	<ul style="list-style-type: none"> • Please disconnect the printer cable and then connect it again. • Please uninstall and then reinstall the printer driver.
Problems in scanning	Scanning error	<ul style="list-style-type: none"> • Data cable of the device is not properly connected. • The scan driver is installed incorrectly. • The LCD screen prompts error messages. 	<ul style="list-style-type: none"> • Ensure proper connection of the data cable. • Reinstall the scan driver.
	Paper feed failure	<ul style="list-style-type: none"> • The printer paper isn't put properly. • The print media is beyond the usage specification range. • The pickup roller is dirty. Too many papers in paper tray. 	<ul style="list-style-type: none"> • Please install the printing medium correctly. If a special printing medium is used, enable the multipurpose feed tray mode. • Please use the print media within the specification range. • Take the excessive papers out from tray. For printing on a special medium, use the multipurpose feed tray.
Problems with Paper Handling	Paper Jam	<ul style="list-style-type: none"> • Too many papers in paper tray. • The print media is beyond the usage specification range. • There is foreign matter in the feed channel. • The pickup roller is dirty. • Internal parts failure. 	<ul style="list-style-type: none"> • Take the excessive papers out from tray. For printing on a special medium, use the multipurpose feed tray. • Make sure to use the paper that meets specifications. For printing on a special medium, use the multipurpose feed tray. • Clean the paper path. • Please clean the pickup roller.
	Print multipage feed	<ul style="list-style-type: none"> • Excessive static electricity on the print media. • The print media is damp or sticks together. • Internal parts failure. 	<ul style="list-style-type: none"> • Re-separate the print media to eliminate some static electricity. It is suggested that you use the recommended print media. • Separate the print media or use better quality and dry print media..

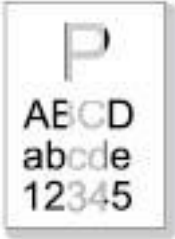
Note: • If the problem persists, please contact the customer service center. See the Three Guarantees certificate for contact details.

Image Defects

Problem	Cause	Solution
 <p data-bbox="169 584 357 656">The printout is whitish or light</p>	<ul style="list-style-type: none"> • The print media does not meet the usage specifications, for example the media is damp or too rough. • The resolution in the print program is set too low, concentration setting is too low, or toner saving mode is ticked. • Toner cartridge is damaged. • Toner is low. 	<ul style="list-style-type: none"> • Please use proper print media within the specification range. • Set the resolution and concentration setting of program, or cancel ticking the save toner mode. • It is suggested to replace the original toner cartridge.
 <p data-bbox="169 943 323 969">Toner spots</p>	<ul style="list-style-type: none"> • Dirty toner cartridge or toner leakage. • Toner cartridge is damaged. • The print media that does not meet usage specification is used. For example, the media is damp or too rough. • The paper path is dirty. • If toner spots appear when copying and scanning, the platen glass may be dirty. • The scanner is dirty or damaged. 	<ul style="list-style-type: none"> • It is suggested to replace the original toner cartridge. • Please use the print media within the specification range. • Clean the paper path. • Clean the platen glass.
 <p data-bbox="169 1397 323 1424">White spots</p>	<ul style="list-style-type: none"> • The print media that does not meet usage specification is used. For example, the media is damp or too rough. • The paper path is dirty. • Inner damage of toner cartridge. • The reflective glass of the laser inside the printer is dirty. 	<ul style="list-style-type: none"> • Please use the print media within the specification range. • Clean the paper path. • It is suggested to replace the original toner cartridge. • Please clean the LSU lens.
 <p data-bbox="169 1727 379 1753">Toner comes off</p>	<ul style="list-style-type: none"> • The print media that does not meet usage specification is used. For example, the media is damp or too rough. • The printing paper medium set and paper medium placed are not consistent. • The inside of the printer is dirty. • Toner cartridge is damaged. • The parts inside the printer are damaged. 	<ul style="list-style-type: none"> • Use the printing medium that meets specifications. For printing on a special medium, use the multipurpose feed tray. • Please print with corresponding paper medium. • Clean the inside of the printer. • It is suggested to replace the original toner cartridge.

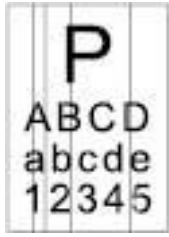

Black vertical stripes

- Dirty toner cartridge.
- Damaged inner parts of toner cartridge.
- The reflective glass of the laser inside the printer is dirty.
- The paper path is dirty.
- If black vertical stripes appear when copying or scanning, the scanner or the platen glass may be dirty.
- Scanner Light bulb has smudges.
- The scanner is damaged.
- Clean or replace toner cartridge
- Clean the mirror of the laser at the back of the printer.
- Clean the feed path of printer.
- Clean the scanner or the platen glass.
- Please use the "Clean & Fix" function to clean the fuser unit of the printer. For how to print, see ["Print a Page for Clean & Fix"](#).



Black background(gray background)

- The print media that does not meet usage specification is used. For example, the media is damp or too rough.
- Dirty toner cartridge
- Damaged inner parts of toner cartridge.
- The paper path is dirty.
- The transfer voltage inside the printer is abnormal.
- Scanning exposure.
- If black background or gray background appears when copying and scanning, the platen glass may be dirty.
- Please use the print media within the specification range.
- Clean or replace toner cartridge
- Clean the paper path inside the printer.
- Please close the cover on the manuscript, and then carry out copying and scanning.
- Clean the platen glass.

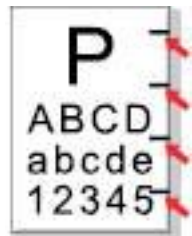

Cyclical traces appear

- Dirty toner cartridge.
- Damaged inner parts of toner cartridge.
- The fuser component is damaged.
- Clean or replace toner cartridge
- Please contact customer services center to replace to a new fuser assembly.



Skewed pages

- The printer paper isn't put properly.
- The feed channel of the printer is dirty.
- Make sure the print paper is placed correctly.
- Clean the paper path inside the printer.



Wrinkled paper

- The printer paper isn't put properly.
- The print media does not meet the usage specification.
- The feed channel of the printer is dirty.
- The fuser component is damaged.
- Make sure the print paper is placed correctly.
- Please use print media within the specification range.
- Clean the paper path inside the printer.
- Please contact customer services center to replace to a new fuser assembly.

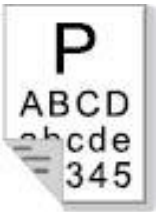

The back of the printout is dirty

- Dirty toner cartridge
- The transfer roller inside the printer is dirty.
- The transfer voltage inside the printer is abnormal.
- Clean or replace toner cartridge
- Clean the internal transfer part of the printer.



Whole page dark

- Toner cartridge is improperly installed.
- Inner damage of toner cartridge.
- Abnormal internal charging of machine or the toner cartridge is not charged.
- If all-black image appear when copying and scanning, maybe it is scanning exposure, and the cover on the manuscript is not properly closed.
- The scanner is damaged.
- Install ink cartridge correctly.
- It is suggested to replace the original toner cartridge.
- Please close the cover on the manuscript, and then carry out copying and scanning.



The toner does not adhere to the paper

- The print media that does not meet usage specification is used. For example, the media is damp or too rough.
- The inside of the printer is dirty.
- Toner cartridge is damaged.
- The parts inside the printer are damaged.
- Use the printing medium that meets specifications. For printing on a special medium, use the multipurpose feed tray.
- Clean the inside of the printer.
- It is suggested to replace the original toner cartridge.

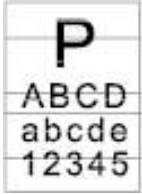

Horizontal stripes

- The toner cartridge is not installed correctly.
- The toner cartridge may be damaged.
- The parts inside the printer are damaged.
- Install ink cartridge correctly.
- It is suggested to replace the original toner cartridge.

Note: • The faults above can be mitigated by cleaning or replacing the cartridge. If the problem persists, please contact the customer service center. See the Three Guarantees certificate for contact details.

12 Product Specifications

Note: • Specification values are slightly different for different models of printers with different functions . These values are based on the initial data. For more information about the latest specification, please visit: www.pantum.com.

Overview of the Specifications

Product Size(W*D*H)	416mm*365mm*370mm
Product weight (including cartridge supplied along with the printer, excluding the package)	12.5Kg
Product weight (including cartridge supplied along with the printer and package)	14.7Kg
Print Environment	Optimal Printing Temp Range:10-32°C Print humidity range:20%RH~80%RH
Power Voltage	110V Model: AC100~127V, 50Hz/60Hz,14A 220V Model: AC220~240V, 50Hz/60Hz,7A
Noise (acoustic pressure level)	Print/scan: ≤54dB(A) Copying: ≤57dB(A) Standby: ≤30dB(A) Mute mode: ≤46 dB (A)
Enter network standby time	1 minutes
Default auto shutdown time (EU Only)	4 hours
Power Consumption	Print: Average ≤650W Standby: <60W Sleep: <1W Shutdown: <0.5W Network standby: Wi-Fi<3W;Non-Wi-Fi<2W TEC: conforming to requirements of EnergyStar and Chinese energy efficiency rating
Operating system	Microsoft Windows XP (32 bit) / Windows 7/ Windows 8.1/ Windows 10 (32/64 bit) / Windows 11 (64 bit) / Windows Server 2012/ Windows Server 2016/ Windows Server 2019/ Windows Server 2022 (64 bit)

	macOS 10.10/10.11/10.12/10.13/10.14/10.15/11.6/12.0.1/12.3/12.4/12.5/13 Linux (Ubuntu 16.04 (32/64 Bit) /18.04/20.04/22.04 (64 Bit) LTS; Debian 10.0/11.0(32/64 Bit) ;Redhat 8.0/9.0 (64 Bit) ;Astra Linux Special Edition V1.6/V1.7 (64 Bit) ; Centos 7 (32/64 Bit)) / Centos 8.2 (64 Bit) iOS 7.0-13.0 Android 5.1-10.0
Communication interface	USB 2.0(High Speed) Wired network: IEEE 802.3 10/100/1000Base-Tx Wi-Fi (2.4G/5G): IEEE 802.11a/b/g/n
Frequency Band	Wi-Fi 2.4GHz : 2400MHz – 2483.5MHz Wi-Fi 5.1GHz : 5150MHz - 5350MHz Wi-Fi 5.8GHz : 5725MHz - 5850MHz
Note: The above frequency bands are common frequency bands, and different markets will restrict the use of certain frequency bands according to the country's regulatory requirements.	
Maximum output power (Declaration for EU Compliance)	WLAN 2.4GHz : 19.00dBm EIRP WLAN 5GHz : 17.00dBm EIRP WLAN 5.8GHz : 13.50dBm EIRP

Print Specifications

Print Speed	40ppm(A4)/42ppm(Letter)
Print Time of First Page	≤8.5sec
Print Language	PDL

Copy Specifications

Copy Speed	40cpm(A4)/42cpm(Letter)
FCOT	Flatbed <10 seconds ADF <12 seconds
Maximum Pages for Successive Print	99 pages
Zoom Ratio	25%~400%
Other Copy Functions	ID copy, Receipt copy, N-up copy, Clone copy, Poster Copy, Collated Copy

Scan Specifications

Scan Type	Flatbed+ADF
Maximum Scan Size	Flatbed: 216×297mm ADF: 216×356 mm
Chromoscan	Yes
Scan Output Function	Scan to E-mail, PC, FTP, SMB, USB flash disk

PANTUM